



## Mitsubishi Triton MV 2024+ Predator & Toro Front Bar Fitting Instruction

### **IMPORTANT! – READ BEFORE INSTALLATION**



- When installed in accordance with these instructions, the front protection bar does not affect the operation of the vehicles SRS airbags.
- This product must be installed exactly as per these instructions using only hardware supplied.
- Take a few moments to read instructions thoroughly before beginning work.
- In the event of damage to any bar component please contact OFFROAD ANIMAL to arrange repair/replacement of components.
- Do not use this product for any vehicle make or model other than that specified on these instructions.
- Do not remove labels from this product.
- This product and its fixings must not be modified in any way unless stated in these fitting instructions.
- The installation of this product is recommended for trained personnel.
- These instructions are correct at time of publication. OFFROAD ANIMAL cannot be held responsible for the impact of any changes subsequently made by the vehicle manufacturer. If you find something has changed, please contact us to let us know!
- During installation it is the duty of the installer to check correct operation/clearances of all components.
- If Instructions are to be printed for reference in the workshop, it is recommended that they are printed in colour, for best legibility.



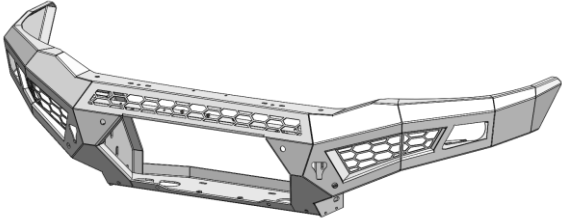
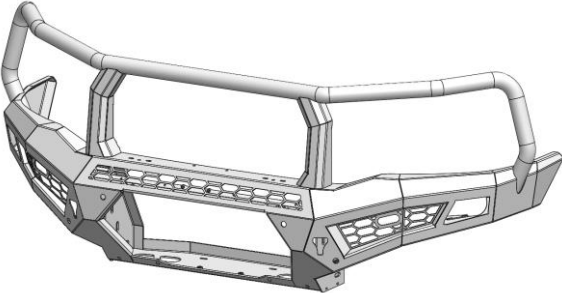
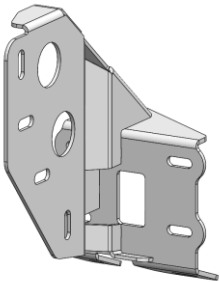
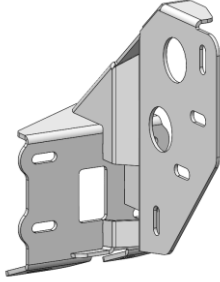

# PARTS LISTING

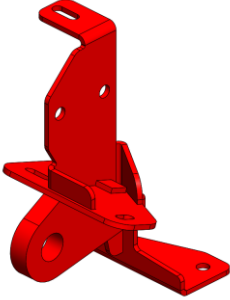
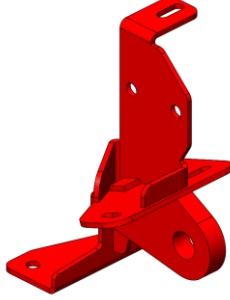
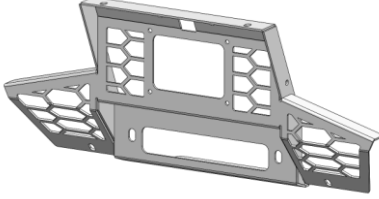
**IMPORTANT:** Check all parts are present before beginning work! Contact OFFROAD ANIMAL if something is missing.

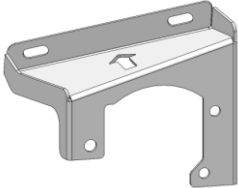
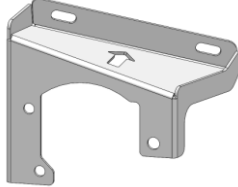
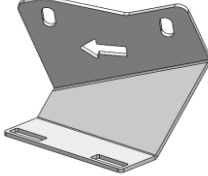
## Parts List

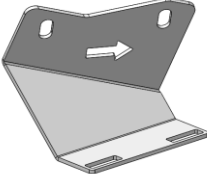

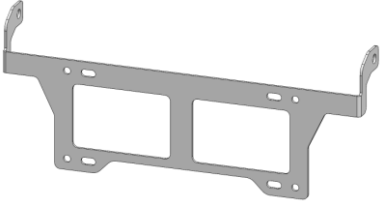
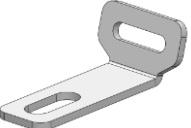
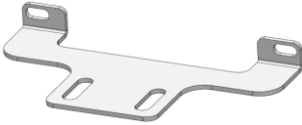
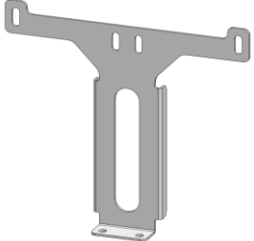
Qty	Part Number	Description	Image
<b>PREDATOR ONLY</b>			
<b>1</b>	FB-MTR-MV-24-PR-ASM1	MV Triton 24+ Predator Bar Welded Assembly	
<b>TORO ONLY</b>			
<b>1</b>	FB-MTR-MV-24-TOR-ASM1	MV Triton 24+ Toro Bar Welded Assembly	
<b>1</b>	FB-MTR-MV-24-PR-ASM2R	MV Triton 24+ Impact Assembly RH	
<b>1</b>	FB-MTR-MV-24-PR-ASM2L	MV Triton 24+ Impact Assembly LH	

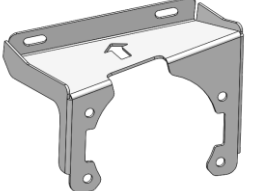
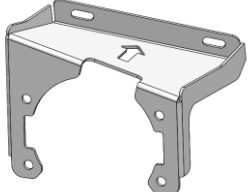

<p><b>1</b></p>	<p>FB-MTR-MV-24-PR-ASM3R</p>	<p>MV Triton 24+ Tow Point Welded Assembly RH</p>	
<p><b>1</b></p>	<p>FB-MTR-MV-24-PR-ASM3L</p>	<p>MV Triton 24+ Tow Point Welded Assembly LH</p>	
<p><b>1</b></p>	<p>FB-MTR-MV-24-PR-ASM4</p>	<p>MV Triton 24+ Mesh Fairlead Welded Assembly</p>	
<p><b>1</b></p>	<p>B-1242</p>	<p>MV Triton 24+ Pan Brace</p>	
<p><b>1</b></p>	<p>B-1243R</p>	<p>MV Triton 24+ LED Fog Light Bracket RH</p>	
<p><b>1</b></p>	<p>B-1243L</p>	<p>MV Triton 24+ LED Fog Light Bracket LH</p>	
<p><b>1</b></p>	<p>B-1250R</p>	<p>MV Triton 24+ Side Radar Bracket RH</p>	

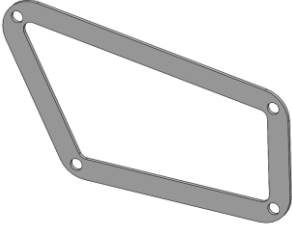
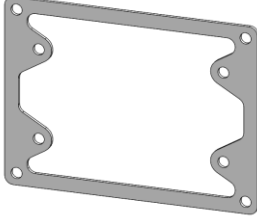
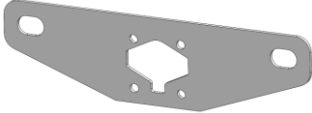
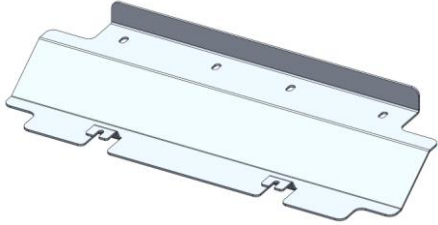
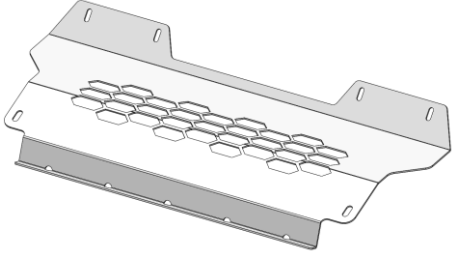
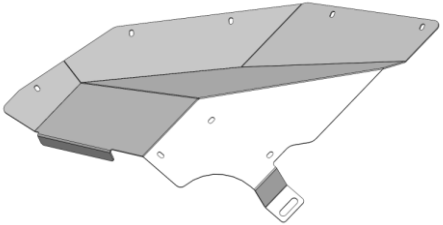
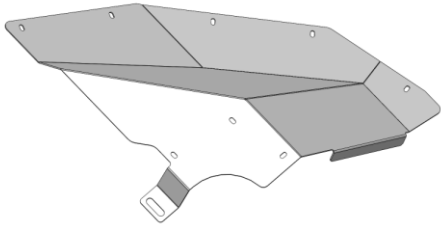
1	B-1250L	MV Triton 24+ Side Radar Bracket LH	
1	B-1253	MV Triton 24+ Camera Cover	
1	B-1254	MV Triton 24+ Number Plate Flip Bracket	
2	B-1255	MV Triton 24+ Lower Side Underpanel Mount	
1	B-1256	MV Triton 24+ GLS/GSR Grille Support Bracket	
1	B-1257	MV Triton 24+ Grille Brace	
1	B-1301	MV Triton 24+ GLX/GLX+ Grille Support Bracket	
1	B-1302R	MV Triton 24+ Halogen Fog Light Bracket RH	
1	B-1302L	MV Triton 24+ Halogen Fog Light Bracket LH	

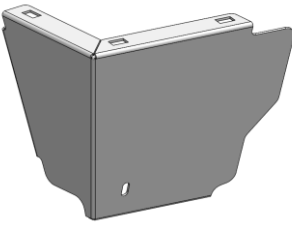
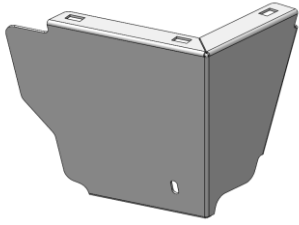

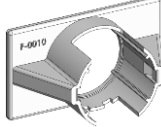
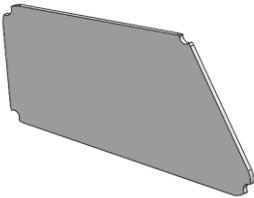
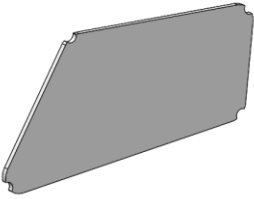
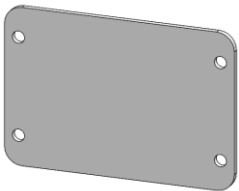
<p><b>2</b></p>	<p>P-0380</p>	<p>MV Triton 24+ Side Radar Cover Mount Plate</p>	
<p><b>1</b></p>	<p>P-0381</p>	<p>MV Triton 24+ Centre Radar Mount Plate</p>	
<p><b>1</b></p>	<p>P-0382</p>	<p>MV Triton 24+ Camera Mount Plate</p>	
<p><b>1</b></p>	<p>U-0082</p>	<p>MV Triton Lower Bash Plate</p>	
<p><b>1</b></p>	<p>U-0083</p>	<p>MV Triton 24+ Centre Bash Plate</p>	
<p><b>1</b></p>	<p>U-0084R</p>	<p>MV Triton 24+ Side Underpanel RH</p>	
<p><b>1</b></p>	<p>U-0084L</p>	<p>MV Triton 24+ Side Underpanel LH</p>	

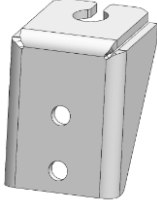
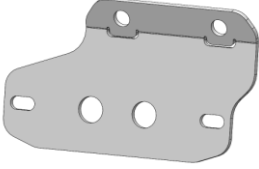
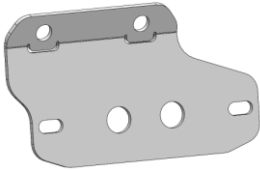
1	U-0085R	MV Triton 24+ Lower Side Underpanel RH	
1	U-0085L	MV Triton 24+ Lower Side Underpanel LH	
1	PWS-TOP-2600	Pinch Weld PWS51T - Top Bulb Seal 2600mm	
1	FB-MTR-MV-24-PR-ADRCP	ADR Compliance Plate Mitsubishi Triton MV 2024+	
4	F-0010	Ford Ranger Next Gen Sensor Holder - Straight	
1	N-0012R	MV Triton 24+ Side Radar Cover Panel RH	
1	N-0012L	MV Triton 24+ Side Radar Cover Panel LH	
1	N-0013	MV Triton 24+ Centre Radar Cover Panel	
1	TK-COM-PSEN-4	Tape Kit - 4 Sensor Universal	N/A

1	OFA-LOGO	Offroad Animal Metal Logo	
1	FI Note	Fitting Instruction Note	N/A
<b>TORO ONLY</b>			
2	B-1244	Toro Antenna Bracket - Tall 8deg	
1	B-1246R	MV Triton 24+ Toro Indicator Repeater Bracket RH	
1	B-1246L	MV Triton 24+ Toro Indicator Repeater Bracket LH	
1	11CAT1M-2	LED Autolamps 11CAT1M-2 Front Indicator - Twin Blister Pack	

**PREDATOR Fasteners – Contained in Small Parts Kit Bag**

Qty	Part Number	Description
64	M6x16 BHCS BLACK ZINC	SCREW, BUTTON HEAD CAP, M6X16X1 GR12.9, ISO4042 ZnNi BLACK PASSIVATED FINISH
3	M6x45 BHCS BLACK ZINC	SCREW, BUTTON HEAD CAP, M6X45X1 GR12.9, ISO4042 ZnNi BLACK PASSIVATED FINISH
67	M6 FLAT WASHER BLACK ZINC	M6 Flat Washer, 12x6.1x1, ISO4042 ZnNi BLACK PASSIVATED FINISH
46	M6 FLANGE NUT	Flange Nut, M6x1 G8.8 ZP
16	M6CN3MM	CAGE NUT M6x2.6-3.5
2	M8 X 20 HEX	Bolt Hex, M8X20x1.25, GR8.8 ZP
2	M8 X 16 BHCS BZP	SCREW, BUTTON HEAD CAP, M8X16X1.25 GR12.9, ISO4042 ZnNi BLACK PASSIVATED FINISH
6	M8 X 25 BHCS BLACK ZINC	SCREW, BUTTON HEAD CAP, M8X25X1.25, ISO4042 ZnNi BLACK PASSIVATED FINISH
8	M8 FLAT WASHER- BLACK ZINC	M8 FLAT WASHER, 16.5x8.4x1.2, ISO4042 ZnNi BLACK PASSIVATED FINISH
2	M8 FLAT WASHER	M8 FLAT WAHER
2	M8 HD FLAT WASHER	M8 FLAT WASHER - High Tensile 19x8x1.9mm
2	M8 NYW	Washer, M8, Nylon
2	M8 NYLOC	NYLOC SELF LOCKING NUT, ST STL A2 ISO
4	M10X20X1.25	Bolt Hex, M10X20x1.25, GR8.8 ZP
8	M10 x 30	Bolt Hex, M10X30x[1.5], GR8.8 ZP
4	M10 Flat Washer	M10 Flat Washer
8	M10 FW LHD	WASHER, FLAT M10X28.5X2.5
6	M10 FLANGE NUT	Flange Nut, M10x1.5 G8.8 ZP
12	M12X30	Bolt Hex, M12X30x1.75, GR8.8 ZP
2	M12X90	Bolt Hex, M12X90x1.75, GR8.8 ZP
16	M12 FW LHD	M12 FW Large Heavy Duty
10	M12 FLANGE NUT	Flange Nut, M12x1.75 G8.8 ZP
2	M12 Nyloc nut	M12 NYLOC NUT
2	NP-COM-M10-190-SLIM	Nut Plate M10 Slim - Suit DMAX Predator
2	NP-COM-M12-300- ASMO	M12 NUT PLATE 300MM STEM
2	P-0311	LC300 Rear Bar Wing Brace Chassis Backing Plate
3	T-0108	MV Triton 24+ Radar Spacer Tube - 23mm
2	T-0109	MV Triton 24+ Crush Tube 59mm

**TORO Fasteners – Contained in Small Parts Kit Bag**

Qty	Part Number	Description
4	M3X12 PAN	SCREW, PAN HEAD PHILLIPS, M3X12X0.5 GR4.6 ZP
4	M3 FLAT WASHER	Flat Washer M3, 7mmODx0.5mm T
4	M3 NUT	Hex Nut, M3x0.5 G48.8 ZP
68	M6x16 BHCS BLACK ZINC	SCREW, BUTTON HEAD CAP, M6X16X1 GR12.9, ISO4042 ZnNi BLACK PASSIVATED FINISH
3	M6x45 BHCS BLACK ZINC	SCREW, BUTTON HEAD CAP, M6X45X1 GR12.9, ISO4042 ZnNi BLACK PASSIVATED FINISH
71	M6 FLAT WASHER BLACK ZINC	M6 Flat Washer, 12x6.1x1, ISO4042 ZnNi BLACK PASSIVATED FINISH
50	M6 FLANGE NUT	Flange Nut, M6x1 G8.8 ZP
16	M6CN3MM	CAGE NUT M6x2.6-3.5
2	M8 X 20 HEX	Bolt Hex, M8X20x1.25, GR8.8 ZP
2	M8 X 16 BHCS BZP	SCREW, BUTTON HEAD CAP, M8X16X1.25 GR12.9, ISO4042 ZnNi BLACK PASSIVATED FINISH
4	M8 X 20 BHCS BLACK ZINC	SCREW, BUTTON HEAD CAP, M8X20X1.25, ISO4042 ZnNi BLACK PASSIVATED FINISH
6	M8 X 25 BHCS BLACK ZINC	SCREW, BUTTON HEAD CAP, M8X25X1.25, ISO4042 ZnNi BLACK PASSIVATED FINISH
12	M8 FLAT WASHER- BLACK ZINC	M8 FLAT WASHER, 16.5x8.4x1.2, ISO4042 ZnNi BLACK PASSIVATED FINISH
2	M8 FLAT WASHER	M8 FLAT WAHER
2	M8 HD FLAT WASHER	M8 FLAT WASHER - High Tensile 19x8x1.9mm
2	M8 NYW	Washer, M8, Nylon
2	M8 NYLOC	NYLOC SELF LOCKING NUT, ST STL A2 ISO
4	M10X20X1.25	Bolt Hex, M10X20x1.25, GR8.8 ZP
8	M10 x 30	Bolt Hex, M10X30x[1.5], GR8.8 ZP
4	M10 Flat Washer	M10 Flat Washer
8	M10 FW LHD	WASHER, FLAT M10X28.5X2.5
6	M10 FLANGE NUT	Flange Nut, M10x1.5 G8.8 ZP
12	M12X30	Bolt Hex, M12X30x1.75, GR8.8 ZP
2	M12X90	Bolt Hex, M12X90x1.75, GR8.8 ZP
16	M12 FW LHD	M12 FW Large Heavy Duty
10	M12 FLANGE NUT	Flange Nut, M12x1.75 G8.8 ZP
2	M12 Nyloc nut	M12 NYLOC NUT
2	NP-COM-M10-190-SLIM	Nut Plate M10 Slim - Suit DMAX Predator
2	NP-COM-M12-300- ASMO	M12 NUT PLATE 300MM STEM
2	P-0311	LC300 Rear Bar Wing Brace Chassis Backing Plate
3	T-0108	MV Triton 24+ Radar Spacer Tube - 23mm
2	T-0109	MV Triton 24+ Crush Tube 59mm

## TOOLS REQUIRED

The following tools will be required to install the product.

Hand Tools	Power Tools	Workshop Equipment
Metric Socket Set 10-19mm	Electric/Air Impact Driver (Optional)	Isopropyl Alcohol
Socket Extension Bar	Soldering Iron	Rag
Metric Spanner Set 10-19mm	Air hacksaw	Cable Ties
Hex (Allen) Key Set 4-6mm	or Jigsaw	Marker pen
Trim Removal Tool	or Multi-tool	Ruler
Plastic Auto Trim Tool Set	or Angle grinder	Measuring tape
Flat Blade Screwdriver Set	Electric drill	Masking tape
Phillips Head Screwdriver Set		Electrical tape
Utility Knife		Heat shrink
Side Cutters		
Pliers		
Wire Strippers		
Precision (jewellery) screwdriver set		
7mm drill bit		

# WORKSHOP SAFETY

It is the responsibility of the installer to always complete works in a safe manner. Make sure the following safety equipment is available and precautions are observed whilst fitting this product.

<p>Hearing Protection</p> 	<p>Always wear ear protection when using power tools.</p>
<p>Eye Protection</p> 	<p>Ensure eye protection is always worn when cutting or drilling.</p>
<p>Manual Handling</p> 	<p>Do not attempt to lift bar assemblies or rock sliders on your own.</p> <p>Always use two people to lift or use mechanical Lifting aid such as hydraulic lifting trolley.</p>
<p>Vehicle Support</p> 	<p>Always ensure vehicle is properly supported when working on it. Do not attempt to fit products whilst suspension work is being carried out. Do not work under a vehicle supported only by a jack.</p>



1. Remove the number plate and set aside.

**TOOLS REQUIRED**

**FASTENERS**



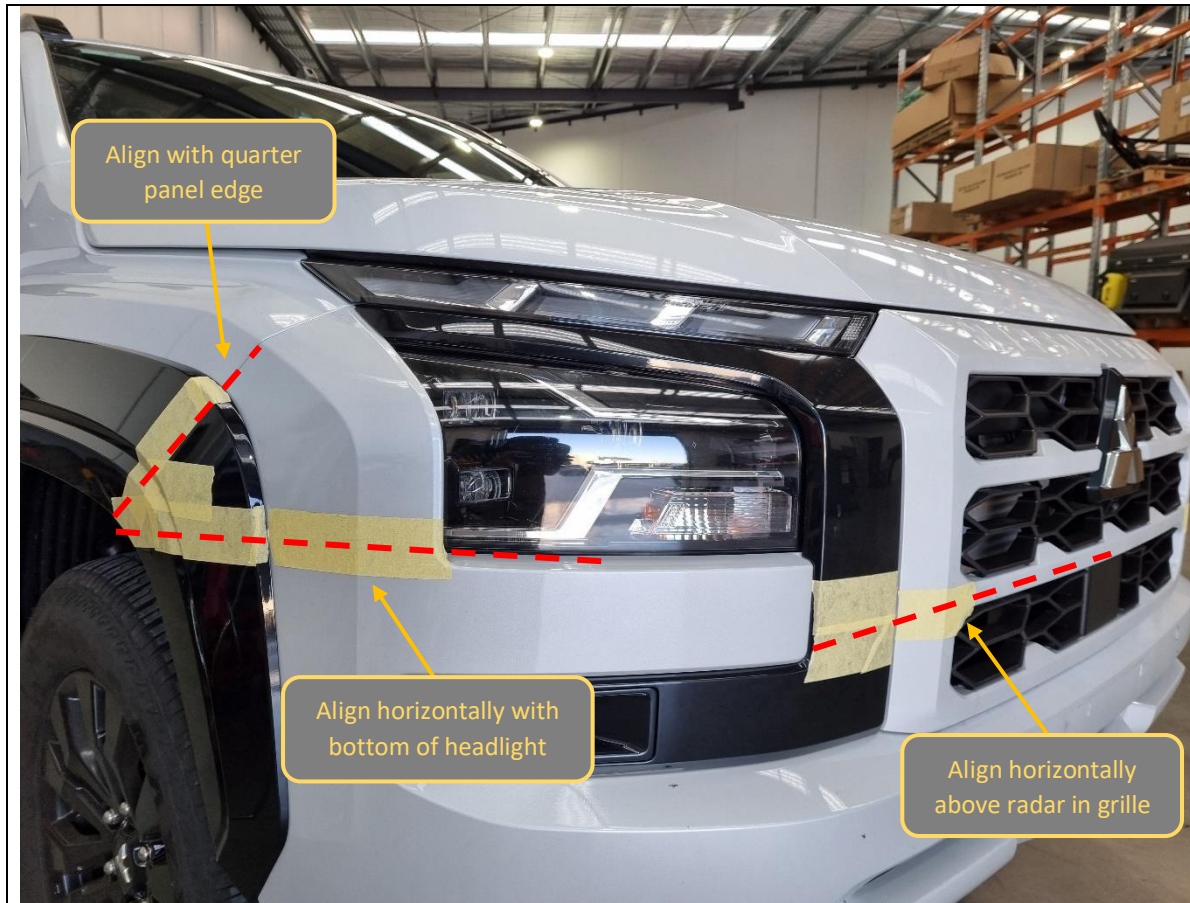

<ol style="list-style-type: none"> <li>2. Apply masking tape on the bumper and grille, as shown (both sides).</li> <li>3. GSR trim level only - also apply masking tape over flare, as shown.</li> </ol>	<p><b>TOOLS REQUIRED</b></p> <p>Masking tape</p>
	<p><b>FASTENERS</b></p>

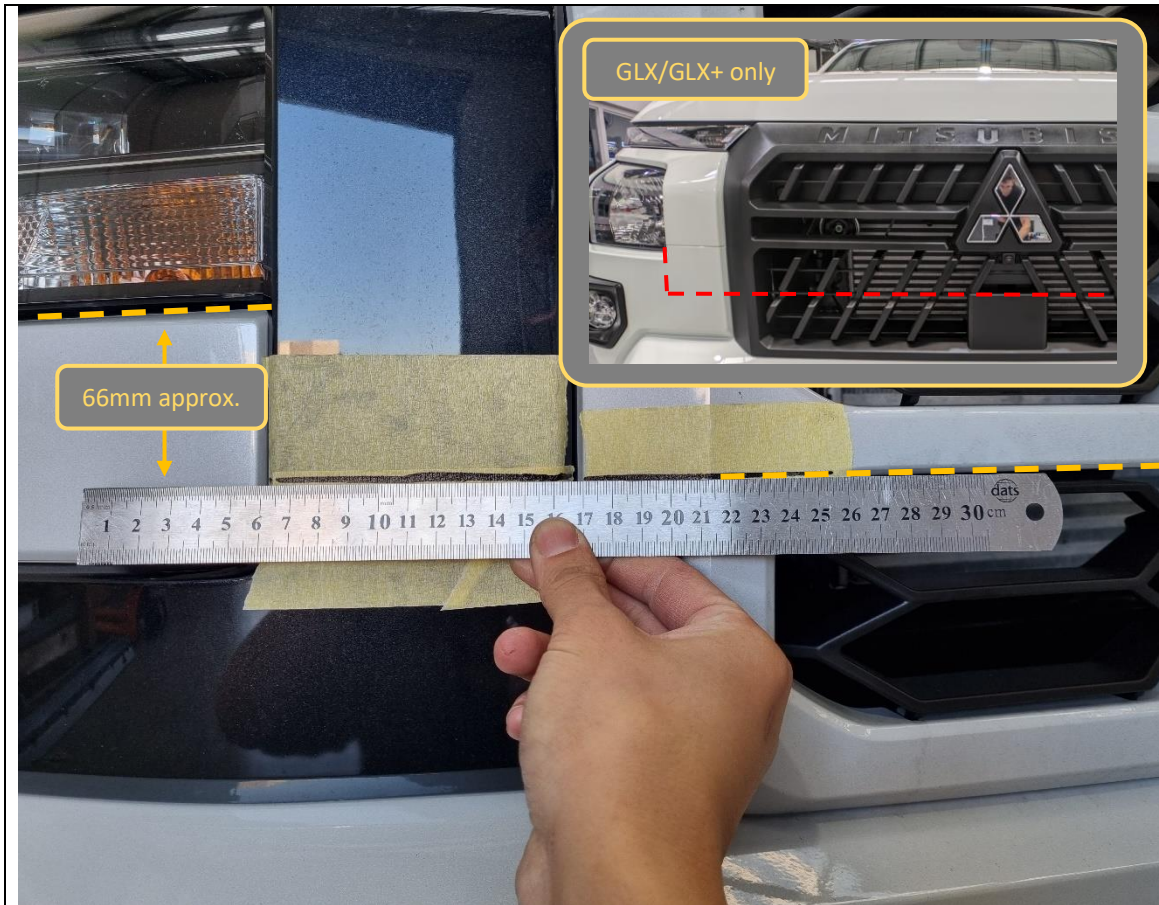

4. Mark out a horizontal cut line across the grille and bumper, approximately 66mm below bottom edge of headlight. (i.e. in line with moulding line in grille)
5. **GLX/GLX+ trim levels.** Also mark a vertical line running parallel with inside edge of headlight (see inset).

**TOOLS REQUIRED**

Marker pen  
Ruler/measuring tape

**FASTENERS**



6. **GSR trim level only.** Mark out a straight line extending from the quarter panel edge onto the flare.

**TOOLS REQUIRED**

Marker pen

Ruler

**FASTENERS**





7. Mark a point along the quarter panel edge, 30mm from the inner wheel arch (see inset).
8. Mark out a horizontal line from the marked point to the bottom edge of the headlight, as shown.

**TOOLS REQUIRED**

Marker pen  
Ruler/measuring tape

**FASTENERS**

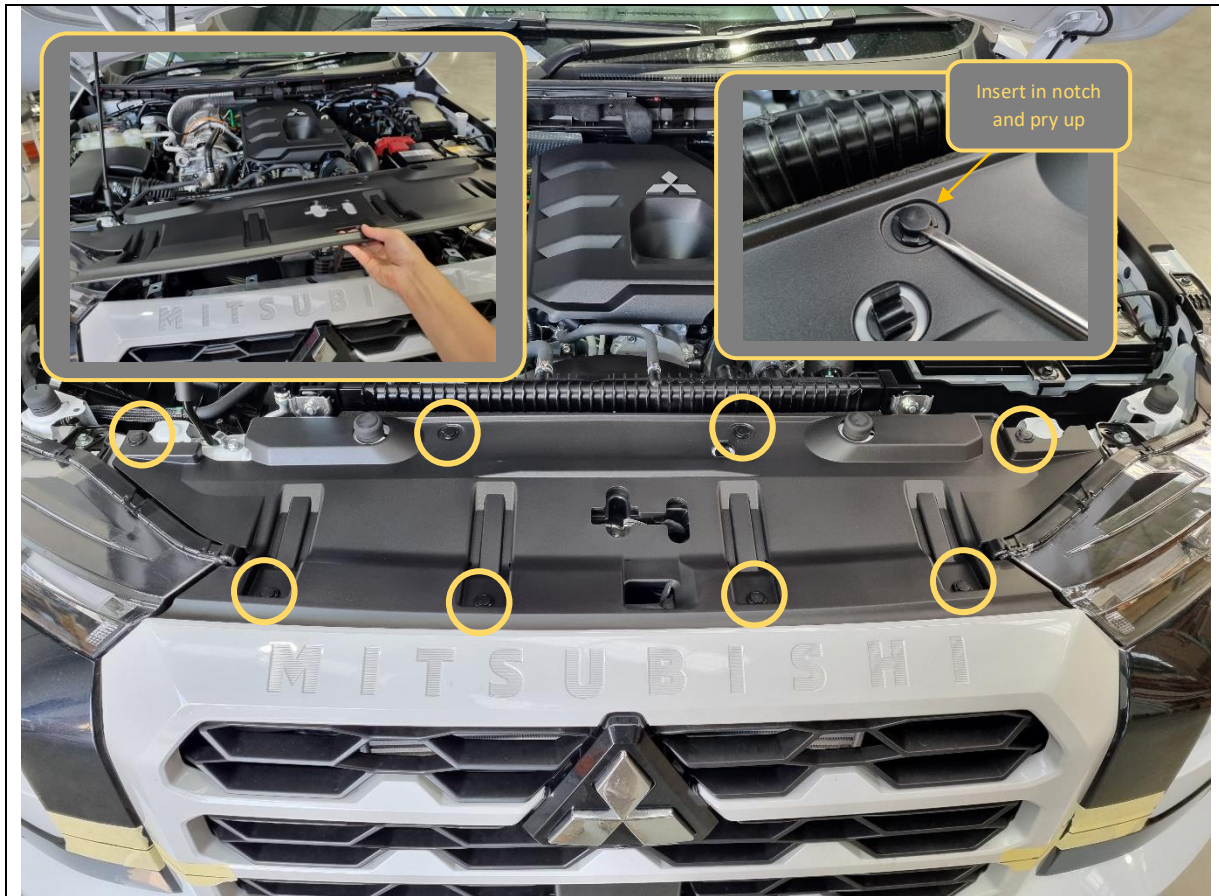

9. Open the bonnet.

10. Remove 8x plastic push clips securing the radiator grille cover, by levering centre section upwards using flat bladed screwdriver or trim tool, as shown.

**TOOLS REQUIRED**

Trim tool  
or  
Flat blade screwdriver

**FASTENERS**

8x Plastic Push Clips  
  
Retain for Reassembly



11. Disconnect the camera plug on the inside of the grille.

**TOOLS REQUIRED**

**FASTENERS**





12. Remove 2x plastic push clips (1x either side) on the top of the grille.

**TOOLS REQUIRED**

Trim tool  
or  
Flat blade screwdriver

**FASTENERS**

2x Plastic Push Clips  
Retain for Reassembly

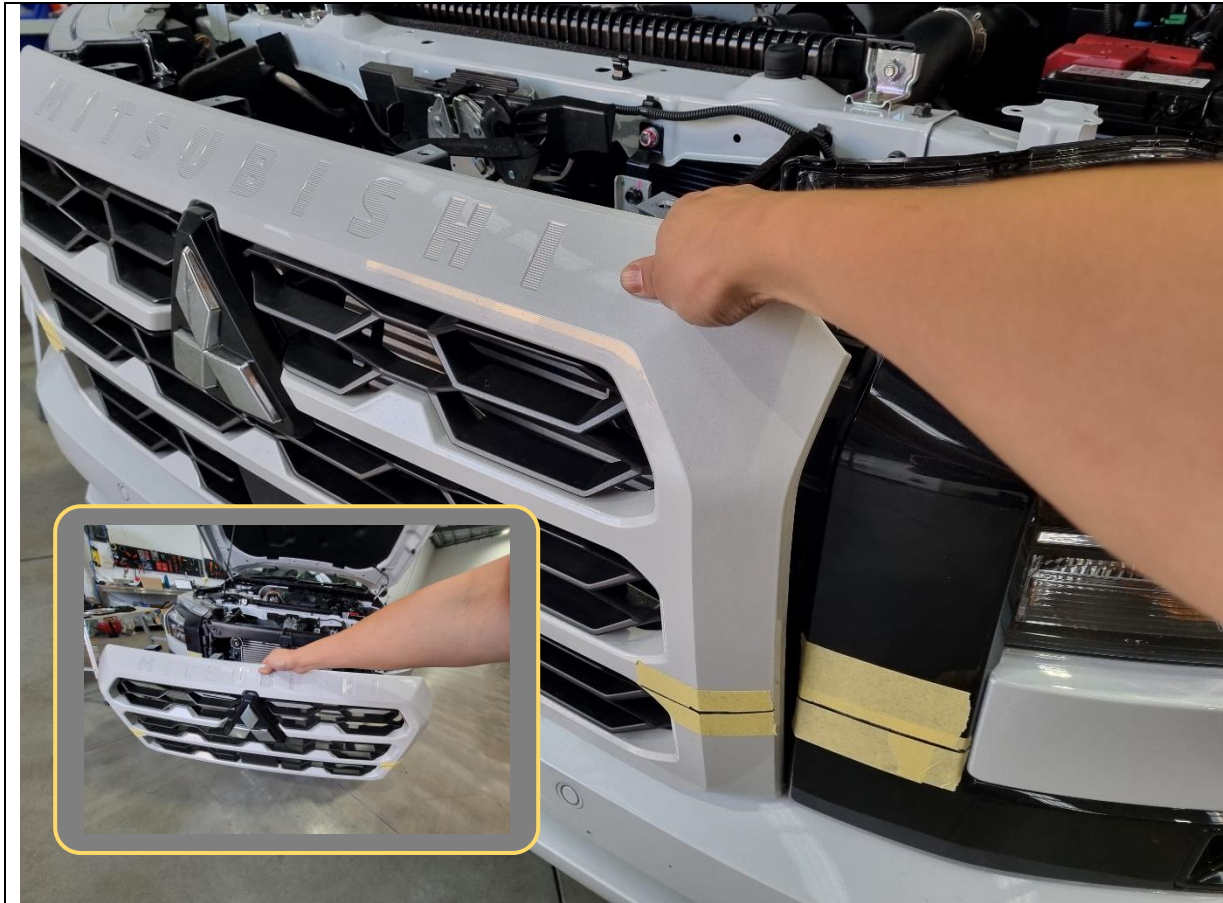

13. Pull outwards from the top and release the clips holding the grille. Set aside for later.

**TOOLS REQUIRED**

**FASTENERS**





- 14. **Non-GSR trim levels.** Remove 3x plastic push clips securing bumper to wheel arch liner (see inset). Do this for both sides.
- 15. The following steps are for GSR flare removal only – all other trim levels skip to **Step 22**.
- 16. Remove 3x 10mm hex bolts holding the front of the flare to the inner wheel arch liner.

**TOOLS REQUIRED**

Trim tool  
or  
Flat blade screwdriver  
  
OR  
  
10mm socket/spanner

**FASTENERS**

6x Plastic Push Clips  
  
OR  
  
3x 10mm factory hex bolts



17. Remove 3x 10mm hex bolts holding the rear of the flare and mudflap.

**TOOLS REQUIRED**

10mm socket/spanner

**FASTENERS**

3x 10mm factory hex bolts

Retain for Reassembly



18. Remove 3x plastic push clips holding the flare to the quarter panel along the upper edge.

**TOOLS REQUIRED**

Trim tool  
or  
Flat blade screwdriver

**FASTENERS**

3x Plastic Push Clips  
  
Retain for Reassembly





19. Gently pull outwards from the two ends to release the clips holding the flare. Set aside for later.
20. Repeat for other side.

**TOOLS REQUIRED**

**FASTENERS**



21. Finish marking the bumper cut line over the area previously hidden by the flare. Check with 30mm reference point from wheel arch liner and re-mark line if necessary.

**TOOLS REQUIRED**

**FASTENERS**



22. Remove the 3x plastic push clips securing bumper to the lower edge of the wheel arch liner (per side).

**TOOLS REQUIRED**

Trim tool  
or  
Flat blade screwdriver

**FASTENERS**

6x Plastic Push Clips



23. Remove the 2x plastic push clips securing the outside bumper (per side).

**TOOLS REQUIRED**

Trim tool  
or  
Flat blade screwdriver

**FASTENERS**

4x Plastic Push Clips





- 24. Remove 1x plastic push clip holding the wheel arch liner and bumper to the quarter panel (per side).
- 25. Remove 1x plastic push clip holding the front of the wheel arch liner to the body (see inset, located above 3x clips from Step 22). Do this for both sides

**TOOLS REQUIRED**

Trim tool  
or  
Flat blade screwdriver

**FASTENERS**

4x Plastic Push Clips  
  
Retain for Reassembly



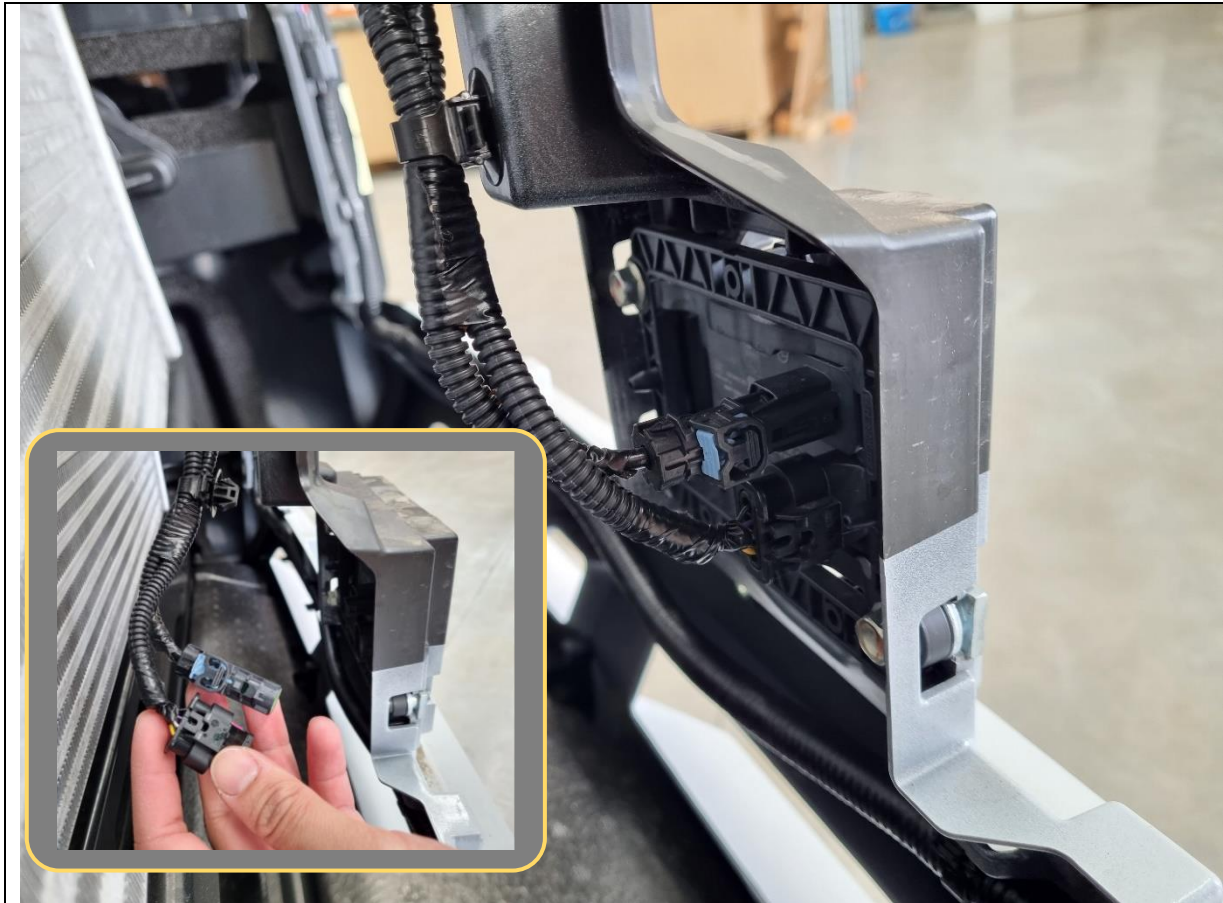

26. Unplug 2x connectors and unclip the wiring harness behind the adaptive cruise control (ACC) radar in the middle of the bumper.

**TOOLS REQUIRED**

**FASTENERS**



27. Unplug and unclip the 2x bumper harness connectors (left and right), located on the bumper near the inside face of the headlights.

**TOOLS REQUIRED**

**FASTENERS**



GLX/GLX+ fog light bezel removed

<p>28. Use a plastic trim tool or flat blade screwdriver/rag combo to unclip fog light bezel.</p> <p>29. Start from the top edge, then work around to the outside edge and pull left/right away from the centre of the car.</p> <p>30. GLS/GSR trim levels have 4x tabs/clips. GLX/GLX+ trim levels have 8x tabs/clips (see top inset).</p>	<p><b>TOOLS REQUIRED</b></p>
	<p><b>FASTENERS</b></p>



31. Remove 1x 10mm hex bolt securing the bumper to the body, next to the fog light. Do this on both sides.

**TOOLS REQUIRED**

10mm socket/spanner

**FASTENERS**

2x 10mm factory hex bolts



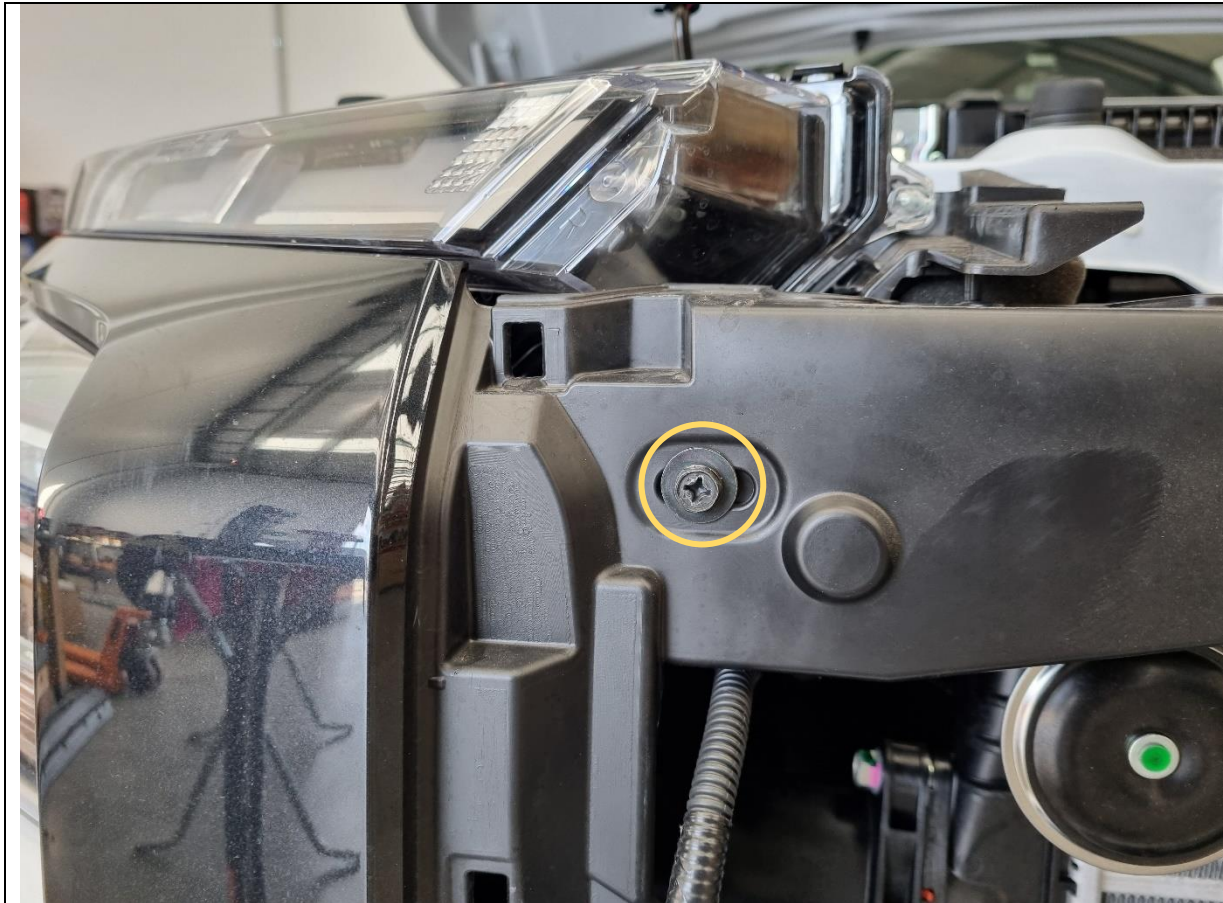

32. Remove 2x 10mm hex bolts on the front face of the bumper near the headlights. Do not discard fasteners.

**TOOLS REQUIRED**

10mm socket/spanner

**FASTENERS**

2x 10mm factory hex screws

Retain for reassembly



- 33. Start from the outer corners of the bumper and pull outwards to release the clips.
- 34. Remove the bumper from the vehicle and set aside.

**TOOLS REQUIRED**

**FASTENERS**

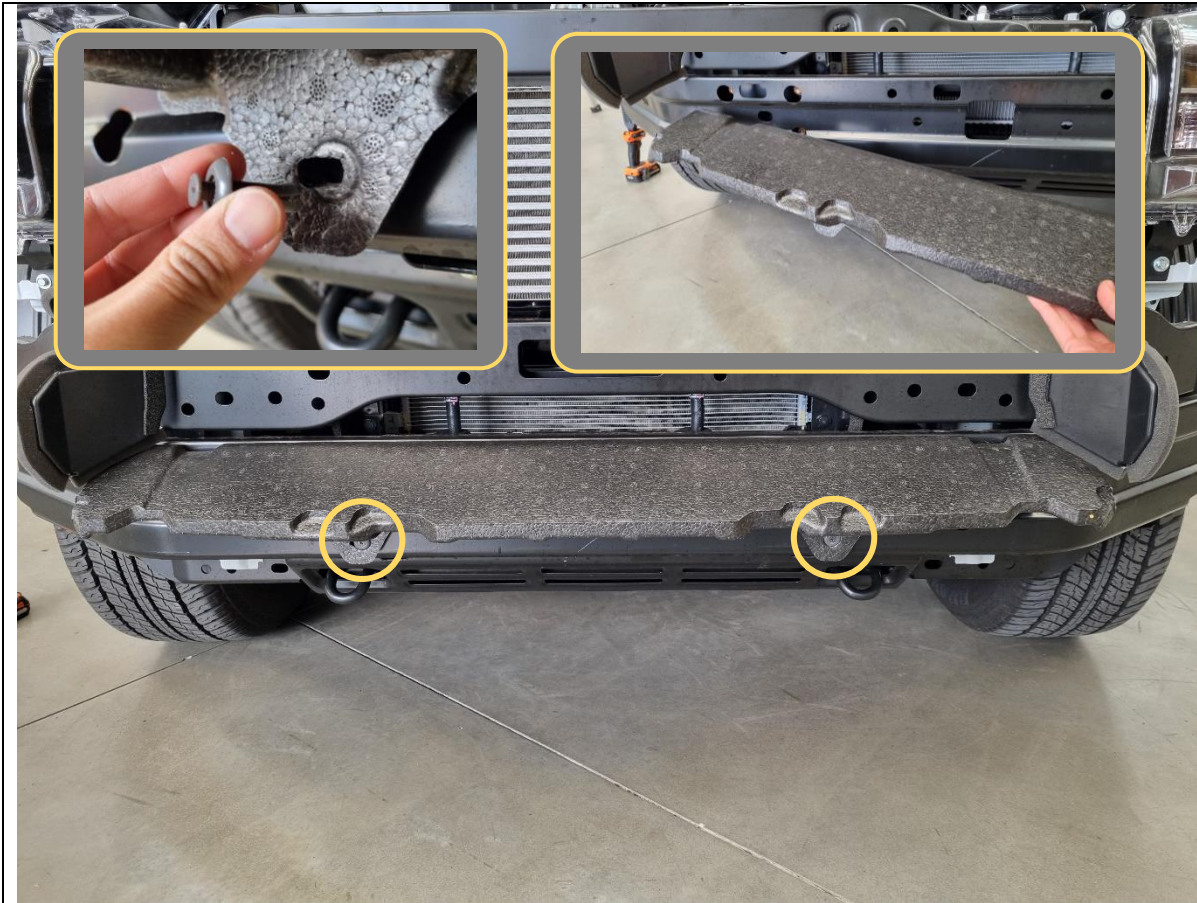

35. Remove 2x plastic scrivenets securing impact foam with a Phillips head screwdriver, then remove impact foam.

**TOOLS REQUIRED**

Phillips head screwdriver

**FASTENERS**

2x plastic scrivenets





- 36. Remove 4x plastic push clips securing the plastic inner air guide on top of the rear of the impact beam.
- 37. Remove and discard the air guide.

**TOOLS REQUIRED**

Trim tool  
or  
Flat blade screwdriver

**FASTENERS**

4x Plastic Push Clips





- 38. Remove 2x 12mm hex bolts securing the metal skid plate to the steel impact beam.
- 39. Loosen the 2x 12mm hex bolts at the rear of the metal skid plate. Leave the bolts threaded onto the chassis.
- 40. Remove and discard the metal skid plate.

**TOOLS REQUIRED**

12mm socket/spanner

**FASTENERS**

4x 12mm factory hex bolts

Retain for reassembly

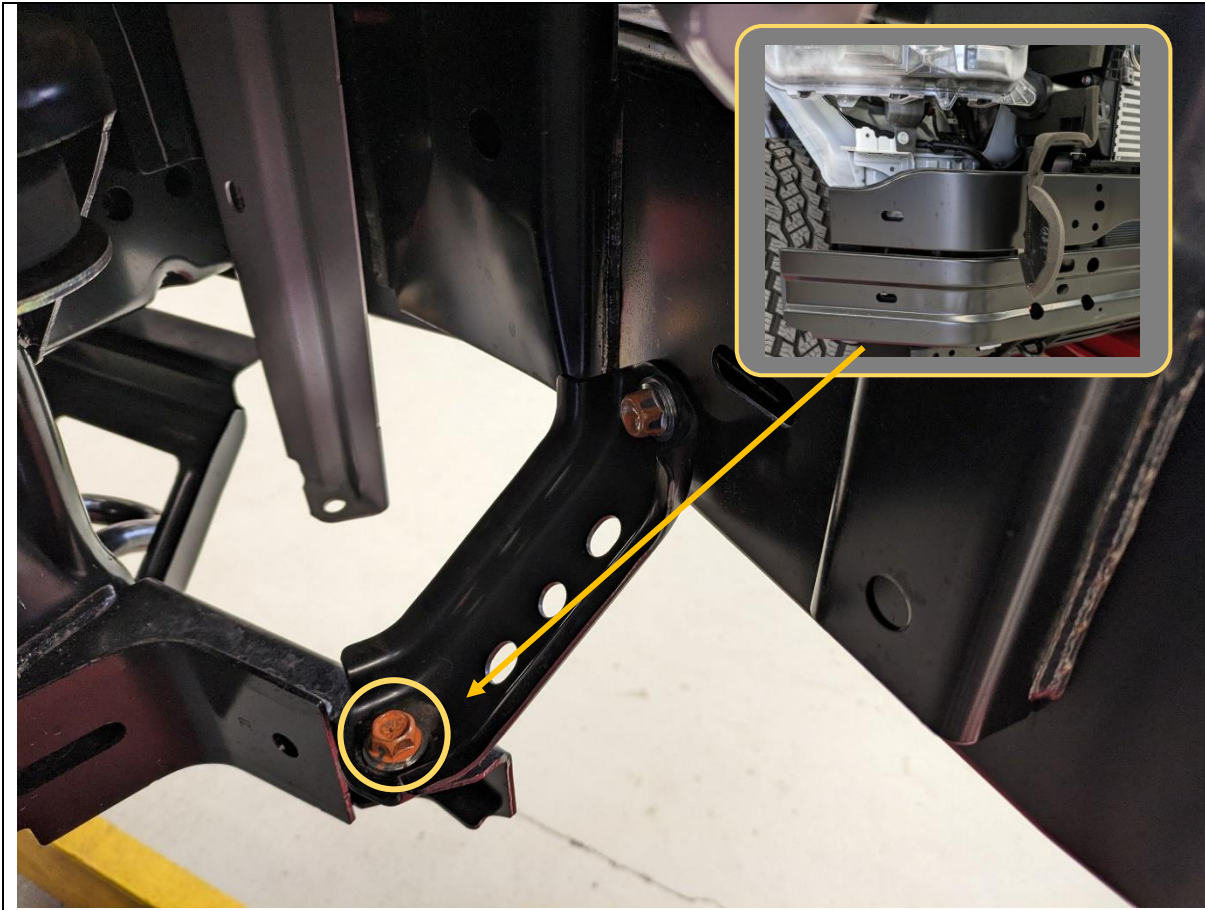

41. Remove 1x 14mm hex bolt securing the outer end of the impact beam to the chassis. The bolt is located behind the impact beam (see inset for location).

42. Repeat for other side.

**TOOLS REQUIRED**

14mm socket/spanner

**FASTENERS**

2x 14mm factory hex bolt

Retain for reassembly



- 43. Remove 8x 14mm hex bolts (4x per side) securing the front face of the impact beam to the chassis.
- 44. Remove and discard the impact beam. Retain the fasteners.

**TOOLS REQUIRED**

14mm socket/spanner

**FASTENERS**

8x 14mm factory hex bolt

Retain for reassembly





45. Remove 2x 12mm hex bolts securing the bumper support bracket to the chassis. Discard the bracket. Repeat for other side.

**TOOLS REQUIRED**

12mm socket/spanner

**FASTENERS**

4x 12mm factory hex bolt

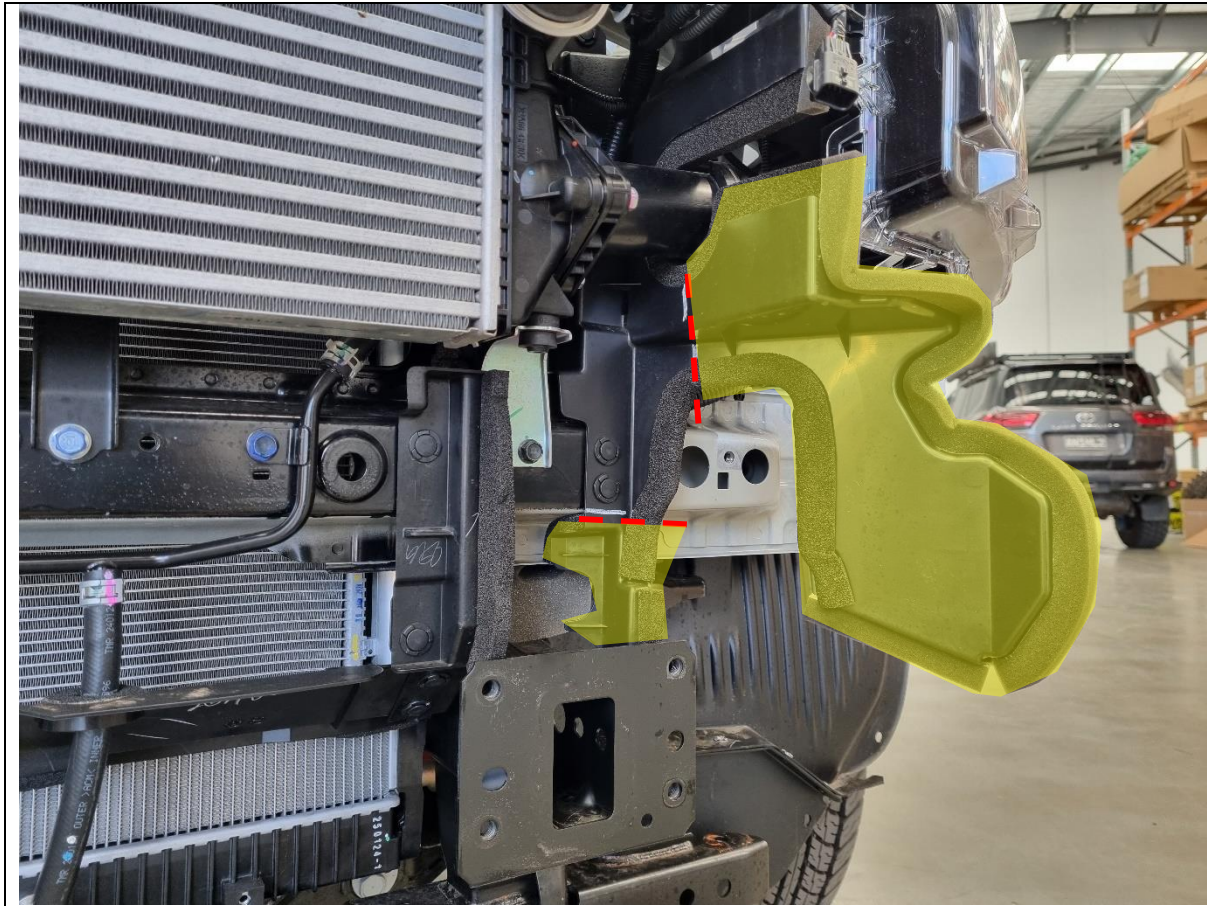

46. Mark the lower air dam in the 2x spots as shown.

**TOOLS REQUIRED**

Marker pen

**FASTENERS**



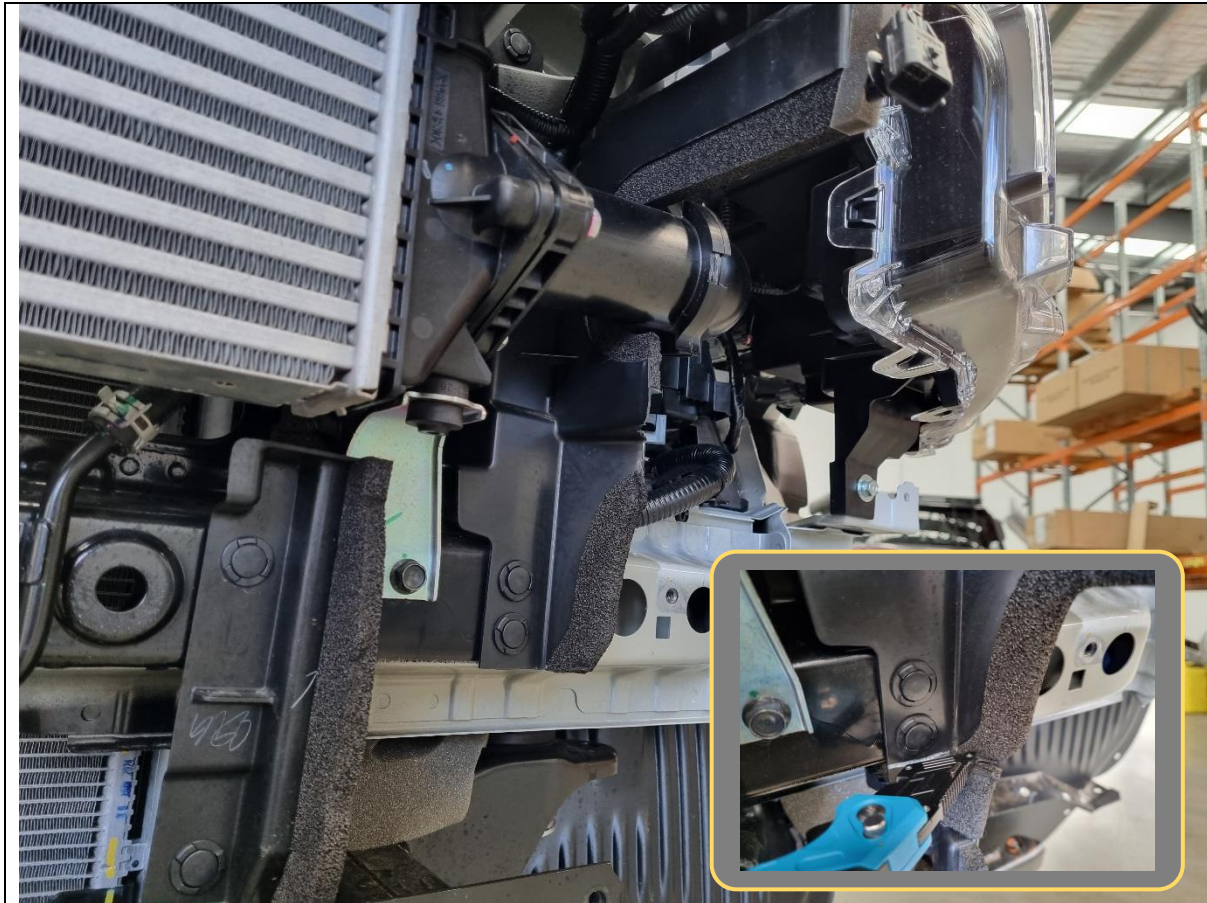

47. Trim the air dam on the car with a utility knife.  
Alternatively unclip the air dam and trim with powered tools.

**TOOLS REQUIRED**

Utility knife  
or  
Air hacksaw/multi-tool/angle grinder

**FASTENERS**

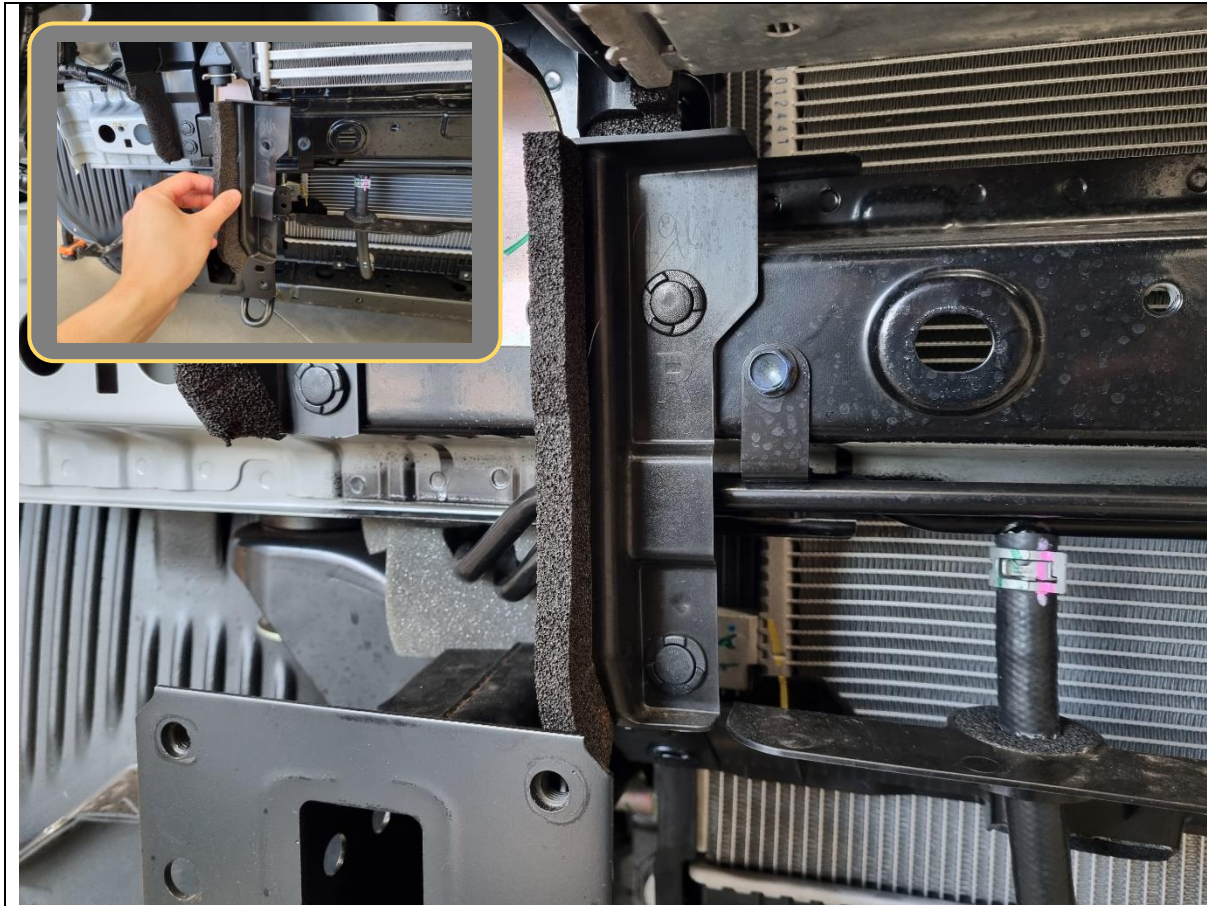

48. Remove 2x plastic push clips securing the mini air dam above the chassis rail. Remove and discard on both sides.

**TOOLS REQUIRED**

Trim tool  
or  
Flat blade screwdriver

**FASTENERS**

4x Plastic Push Clips



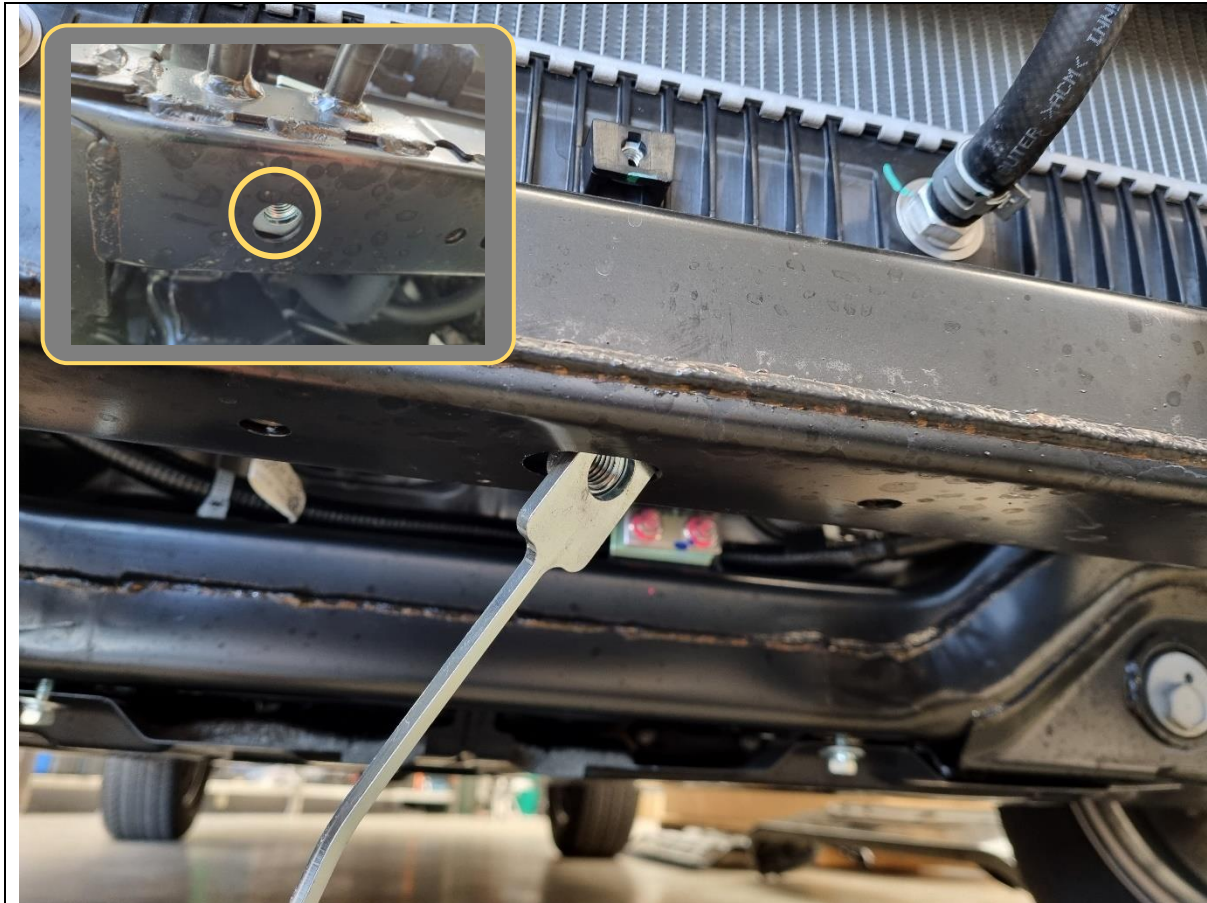

49. Insert 2x M12 nutplates through the large oval hole in the centre of the underside of the lower chassis cross member.
50. Guide the nutplates left/right and align each one with the round hole underneath where the 2x factory tie down hooks are located (see inset).

**TOOLS REQUIRED****FASTENERS**

2x M12 nutplate  
(NP-COM-M12-300-ASMO)



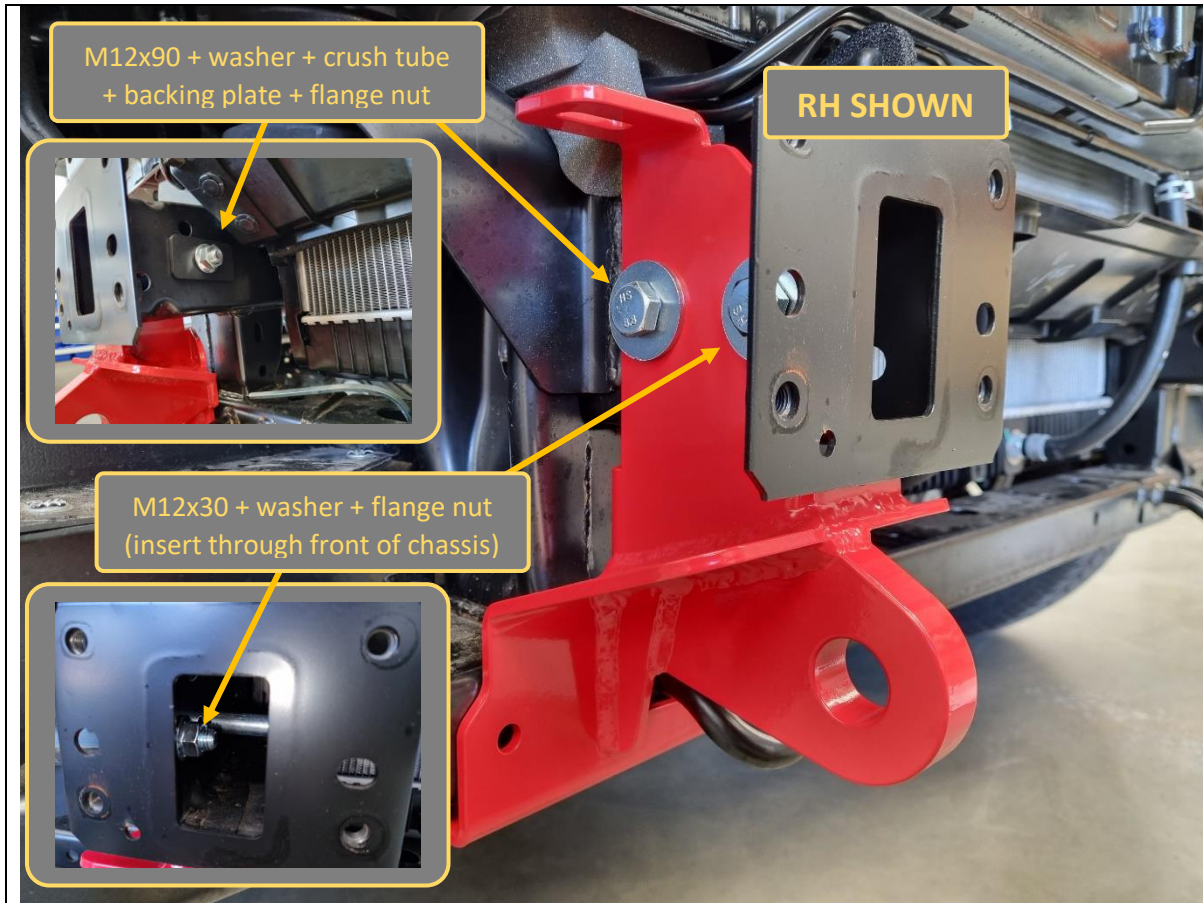

51. Fit the tow point onto the outside face of the chassis rail, then loosely secure with fasteners as shown above. Leave finger tight.

**TOOLS REQUIRED**

**FASTENERS**

- 1x M12x30 hex bolt
- 1x M12x90 hex bolt
- 2x M12 heavy duty washer
- 2x M12 flange nut
- 1x T-0109 59mm crush tube
- 1x P-0311 backing plate

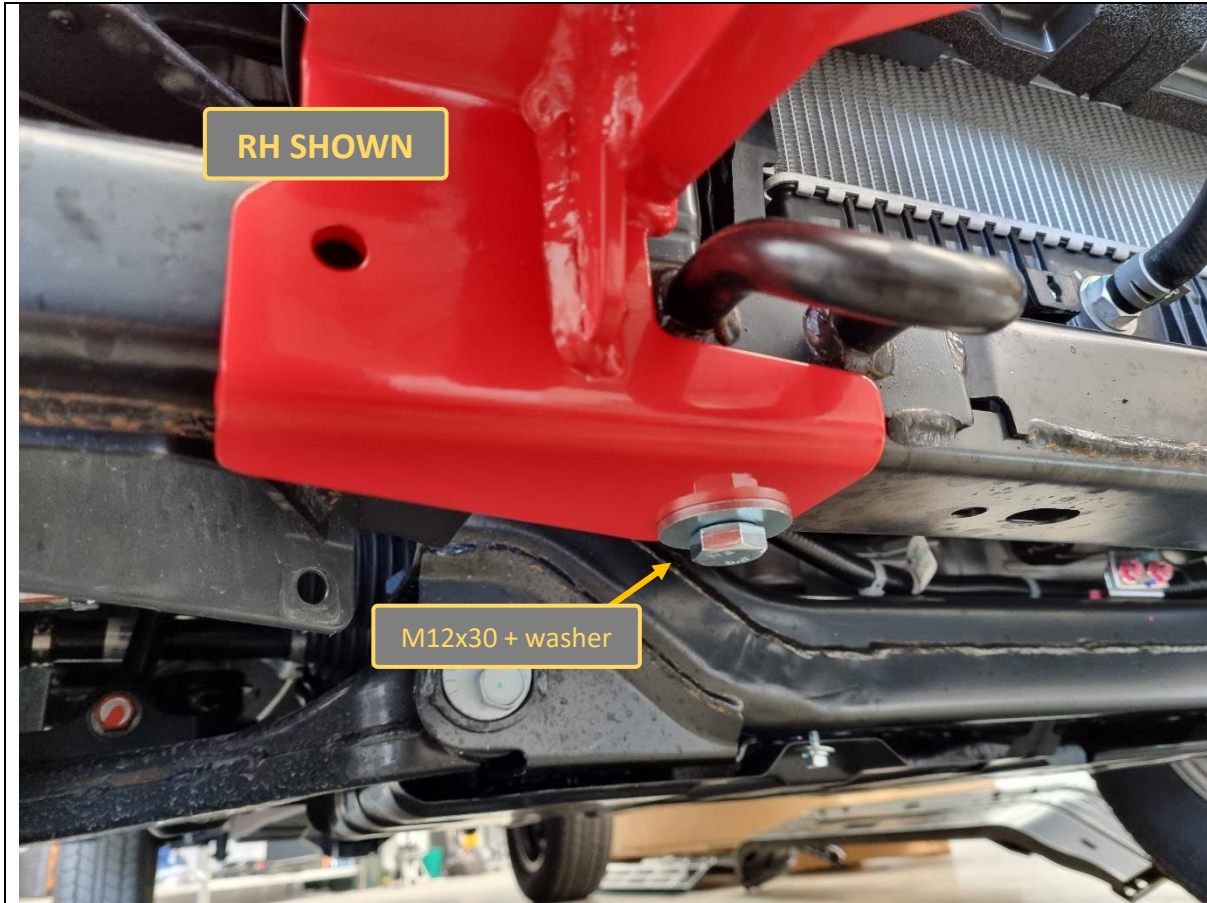

52. Loosely secure the bottom of the tow point with 1x M12x30 hex bolt and heavy duty washer to the M12 nutplate installed previously. Leave finger tight.

**TOOLS REQUIRED**

**FASTENERS**

1x M12x30 hex bolt  
1x M12 heavy duty washer

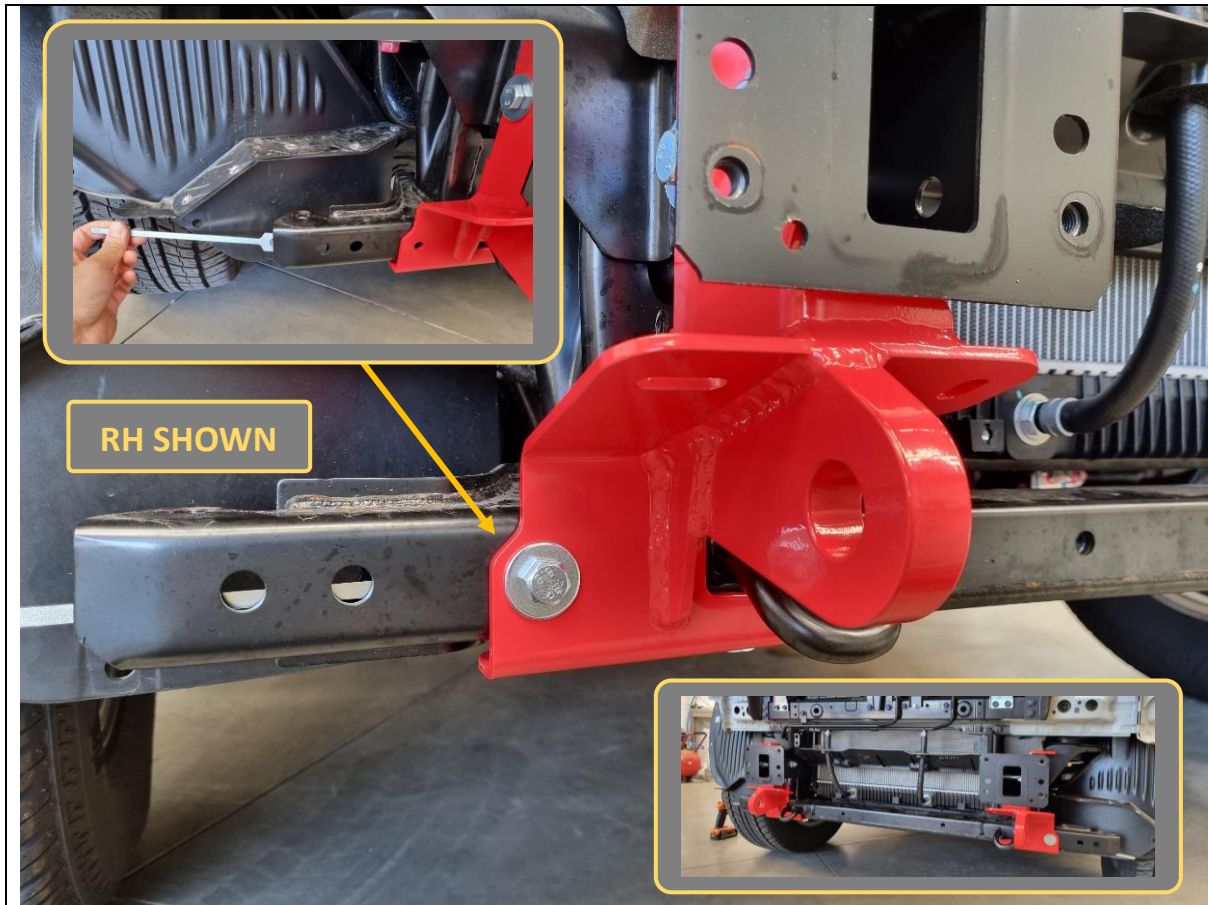

- 53. Insert 1x M10 nutplate through the open outside end of the chassis.
- 54. Loosely secure tow point to the nutplate with 1x M10x30 hex bolt and heavy duty washer. Leave finger tight.
- 55. Complete fitment of other side tow point.

**TOOLS REQUIRED**

**FASTENERS**

1x M10x30 hex bolt  
 1x M10 heavy duty washer  
 1x M10 nut plate  
 (NP-COM-M10-190-SLIM)



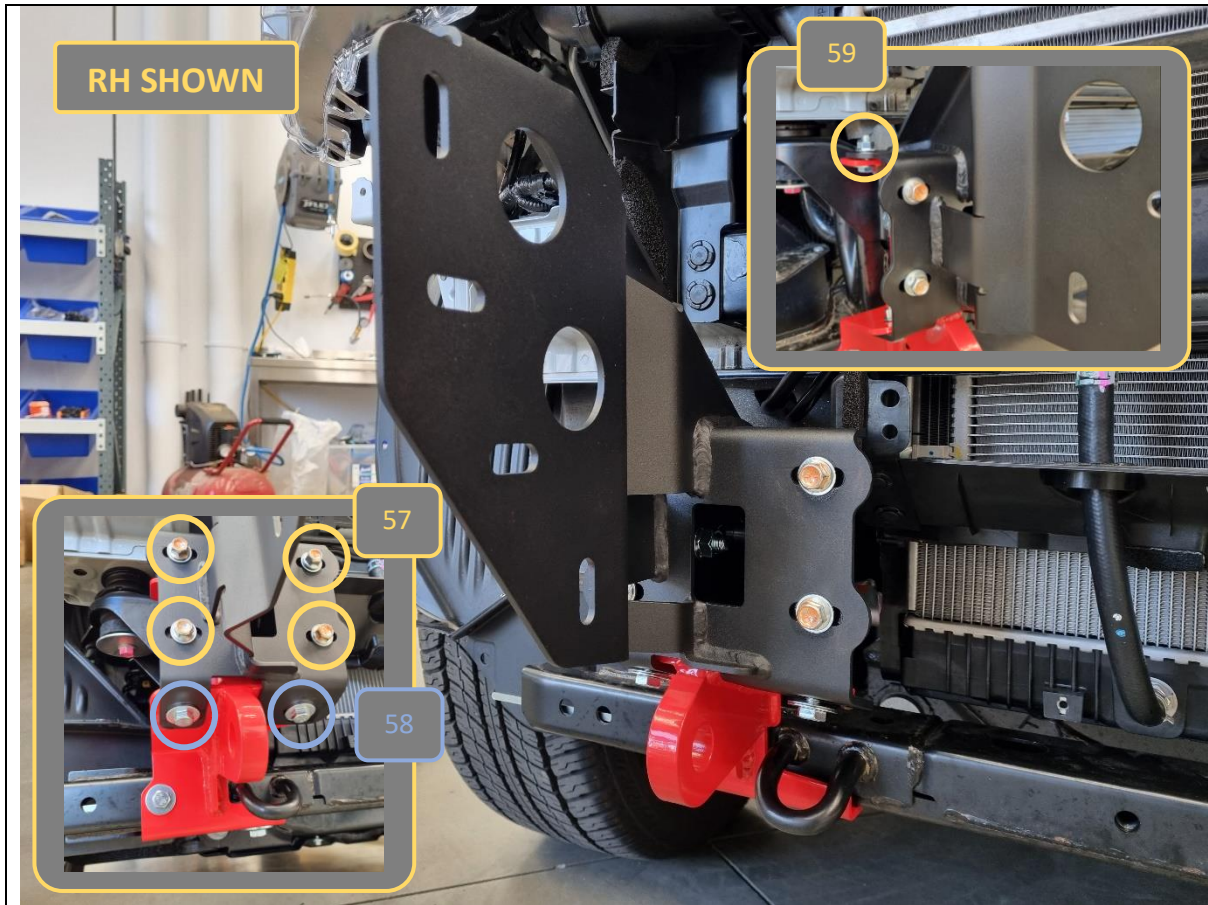

<p>56. Fit the impact assembly onto the chassis ends.</p> <p>57. Loosely secure to the front face of the chassis rail with the retained 4x 14mm factory hex bolts.</p> <p>58. Loosely secure the bottom of the impact assembly with 2x M10x30 hex bolts, heavy duty washers and flange nuts.</p>	<p><b>TOOLS REQUIRED</b></p>
<p>59. Loosely secure the rear top of the impact assembly with 1x M10x30 hex bolt, heavy duty washer and flange nut (bolt on bottom, nut on top).</p> <p>60. Repeat for other side impact assembly. Leave all fasteners finger tight.</p>	<p><b>FASTENERS</b></p> <p>4x 14mm factory hex bolts</p> <p>3x M10x30 hex bolts 3x M10 heavy duty washers 3x M10 flange nuts</p>



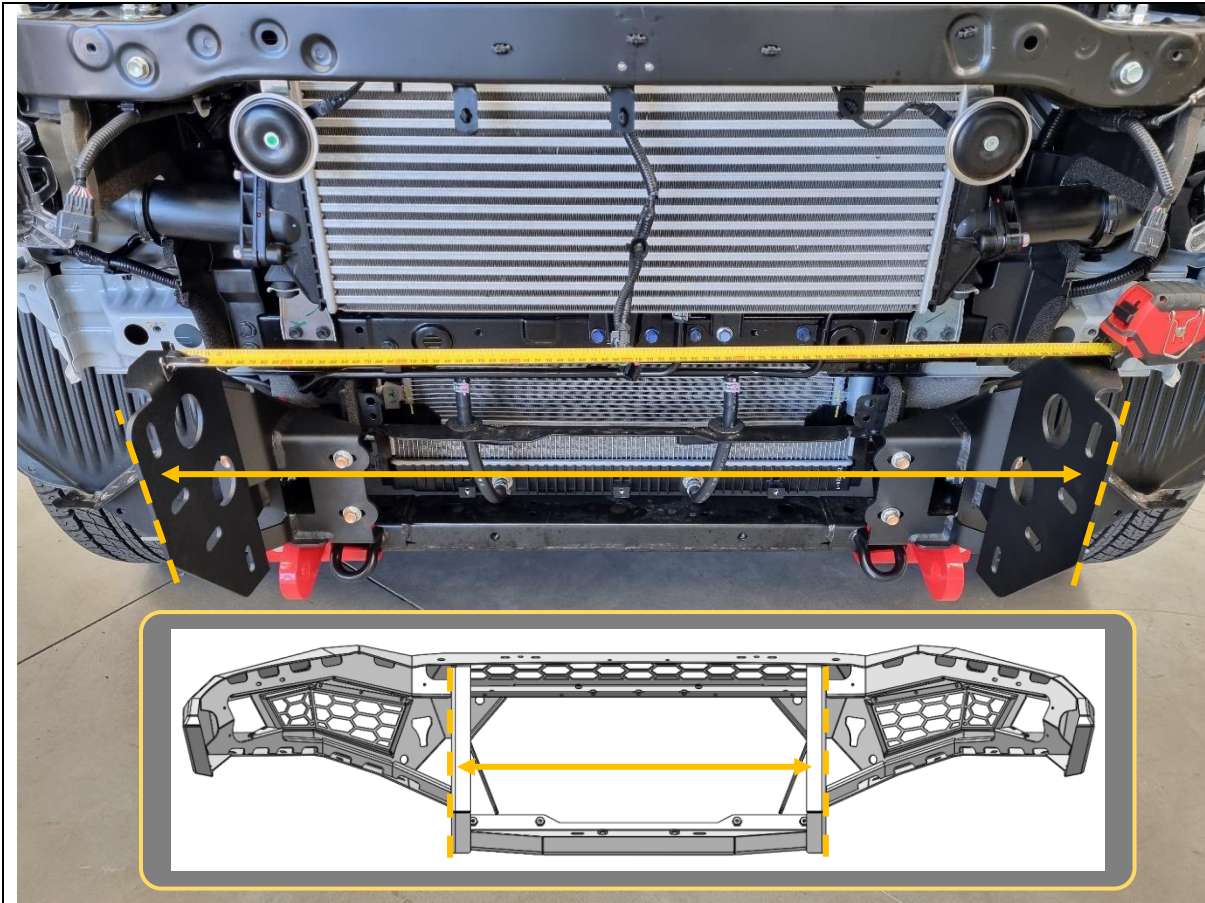

61. Measure the distance between the outside faces of uprights on bar using tape measure. Write distance below for reference if required.

Bar Upright Width = \_\_\_\_\_mm

62. Adjust mounts by sliding left/right on the slots, such that distance between inner faces of mounts are approximately 2mm more than bar. Ensure the mount faces are vertically upright and symmetric left/right on the chassis.

63. Secure and tighten all fasteners holding the impact assemblies and tow points.

**TOOLS REQUIRED**

Tape measure

14mm socket/spanner  
16mm socket/spanner  
19mm socket/spanner

**FASTENERS**



- 64. Fit the lower bash plate to the vehicle.
- 65. Secure the rear of the bash plate with the 2x 12mm factory head bolts left on the vehicle previously.
- 66. Secure the front of the bash plate to the chassis with 4x M10x20x1.25P (fine pitch) bolts and standard washers.

**TOOLS REQUIRED**

- 12mm socket/spanner
- 16/17mm socket/spanner

**FASTENERS**

- 2x 12mm factory hex bolts
- 4x M10x20x1.25P
- 4x M10 flat washer



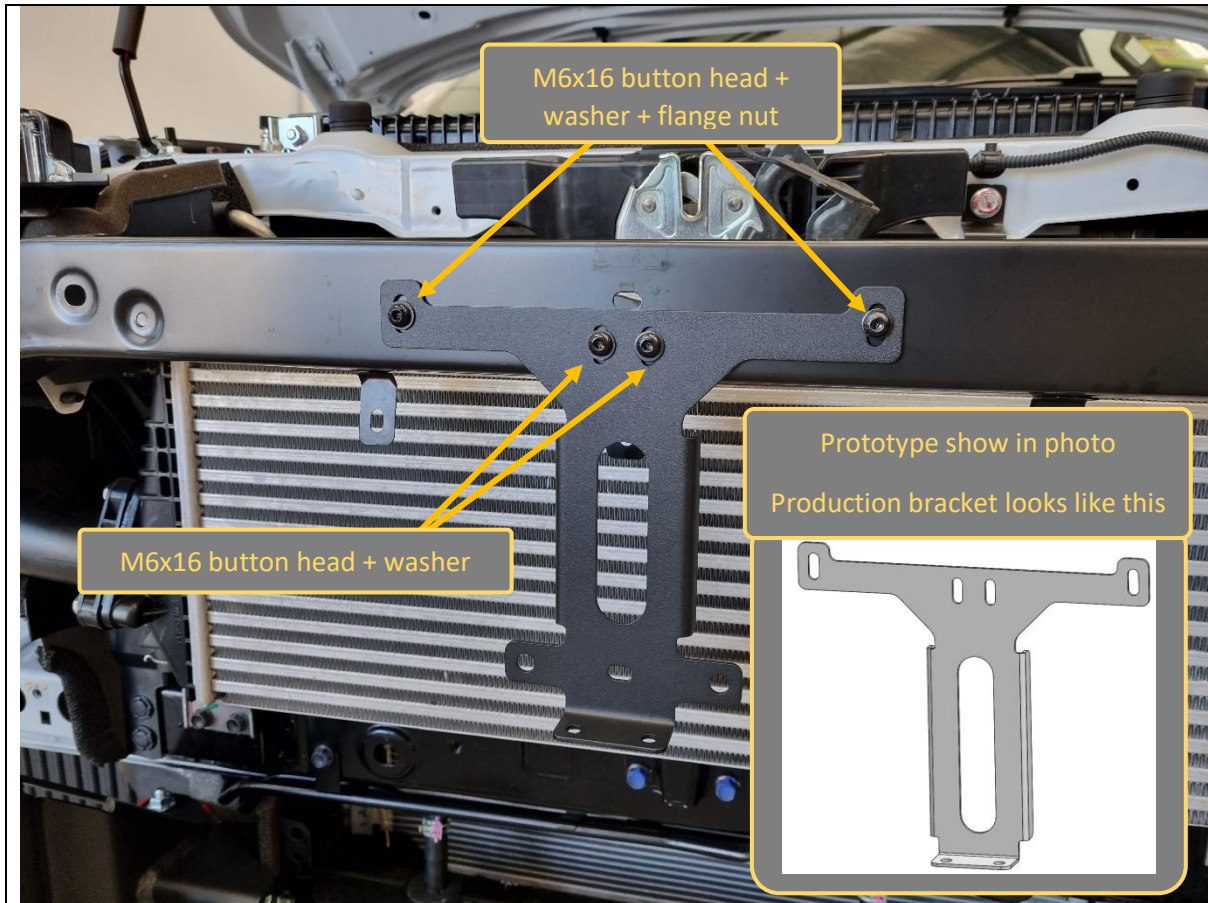

67. Fit the grille brace bracket to the upper body frame. Secure with 4x M6x16 black button head bolts, black washers and flange nuts.

**TOOLS REQUIRED**

4mm hex/Allen key

**FASTENERS**

4x M6x16 black button head  
4x M6 black flat washer  
2x M6 flange nut



68. Unclip the camera harness from the upper body frame and let cable hang down.

**TOOLS REQUIRED**

**FASTENERS**



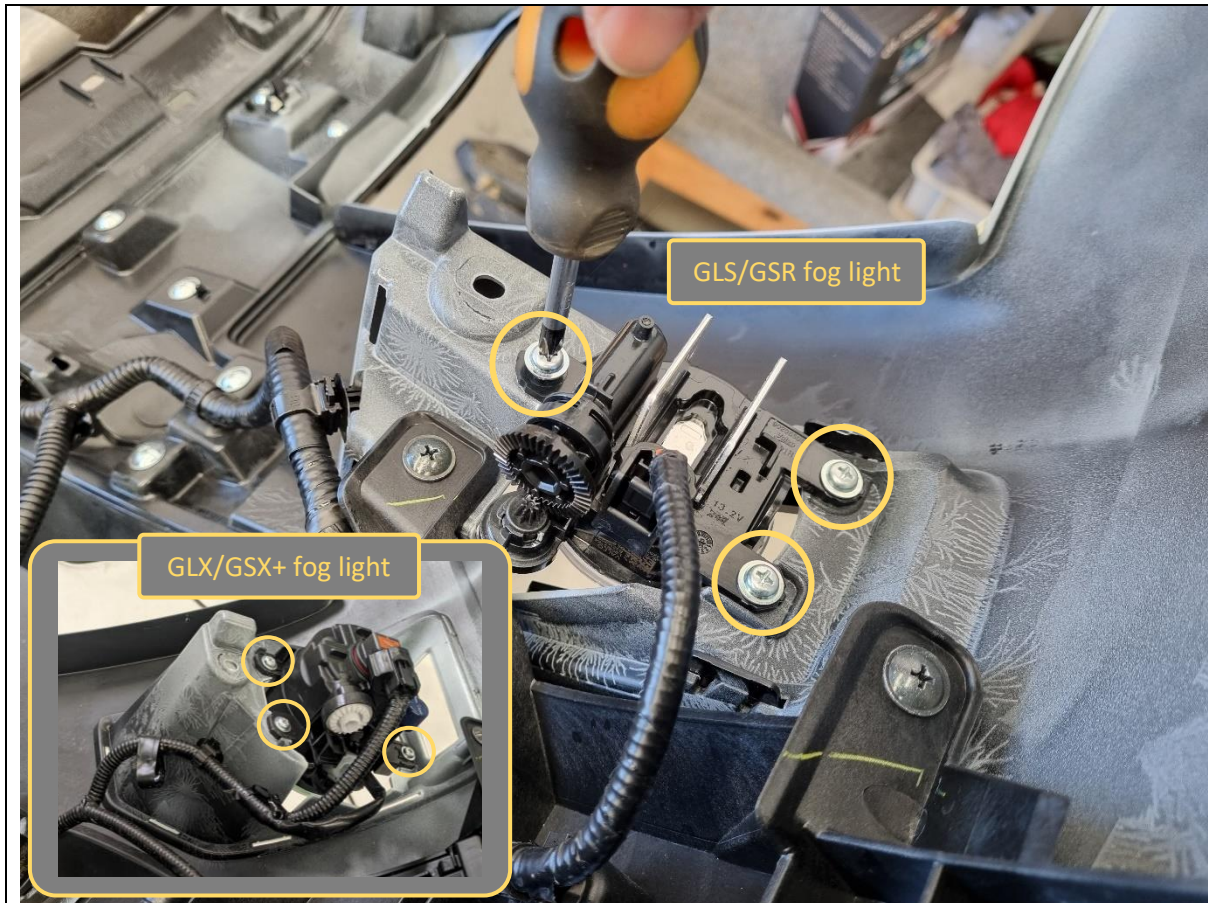

69. Remove the 3x screws holding each fog light to the stock plastic bumper with a Phillips head screwdriver.

**TOOLS REQUIRED**

Phillips head screwdriver

**FASTENERS**

6x factory pan head screws

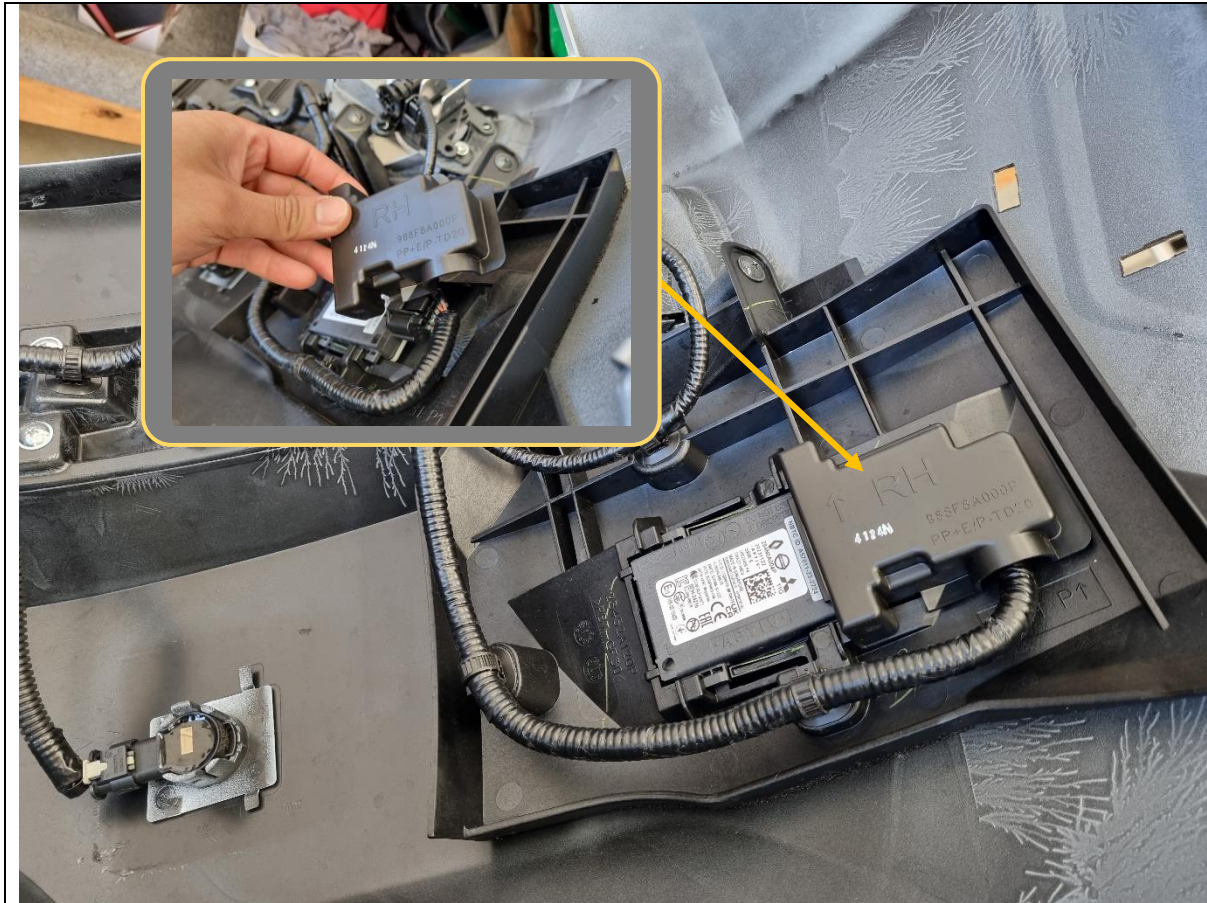

70. Unclip the intersection collision assist (ICA) radar plug plastic cover.

**TOOLS REQUIRED**

**FASTENERS**



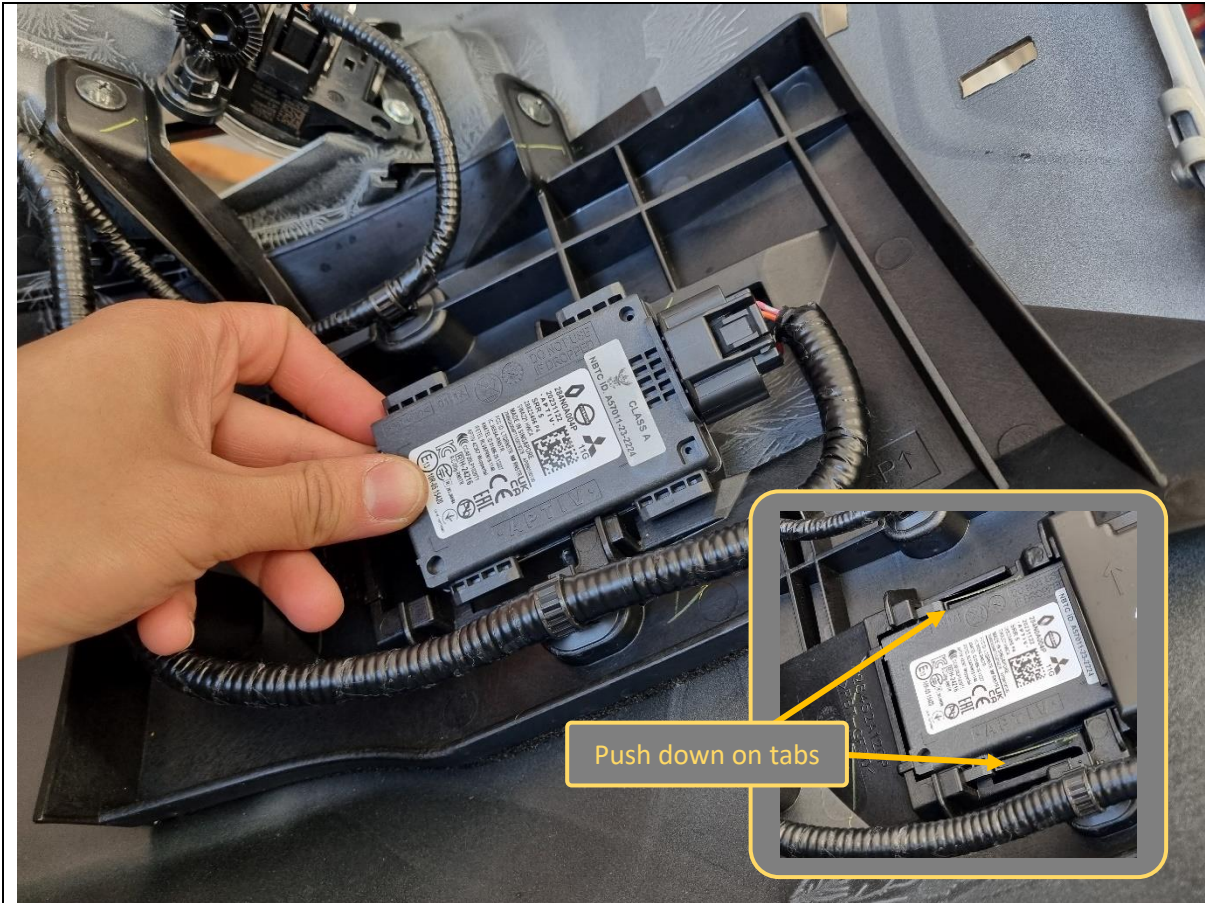

71. Push down on the plastic tabs, then slide the ICA radar outwards and off the bumper. Take note of the orientation of each radar unit and its plug direction before fully removing.

**TOOLS REQUIRED**

**FASTENERS**



72. Unclip all 4x parking sensors from the bumper. Take note of the orientation of each parking sensor and its plug direction (i.e. in/out).

**TOOLS REQUIRED**

**FASTENERS**





73. Unclip the complete harness from the bumper and set aside, with radars and parking sensors attached. Take care not to drop or impact any of the components. Take note of harness orientation.

**TOOLS REQUIRED**

Trim tool  
or  
Flat blade screwdriver

**FASTENERS**



74. Remove 3x 10mm hex bolts securing the middle ACC radar on the bumper. Take note of the radar orientation before removing. Do not drop or impact the radar unit.

**TOOLS REQUIRED**

10mm socket/spanner

**FASTENERS**

3x 10mm factory hex bolts



75. Fit the supplied indicator repeater lamps to the indicator brackets, using 2x M3 Phillips head screws and the adhesive backing included with the lamp module. Do this with both brackets.

**TOOLS REQUIRED**

Small Phillips screwdriver

**FASTENERS**

4x M3x12 pan head screws  
4x M3 washers  
4x M3 hex nuts





76. Fit the indicators and brackets to the inside of the bullbar wing mesh, using 2x M6x16 black button head bolts, black washers and flange nuts. The indicator should sit flush and central to the cutout in the mesh. Do this for both indicators.

**TOOLS REQUIRED**

4mm hex/Allen Key

**FASTENERS**

4x M6x16 black button head  
4x M6 black washer  
4x M6 flange nut



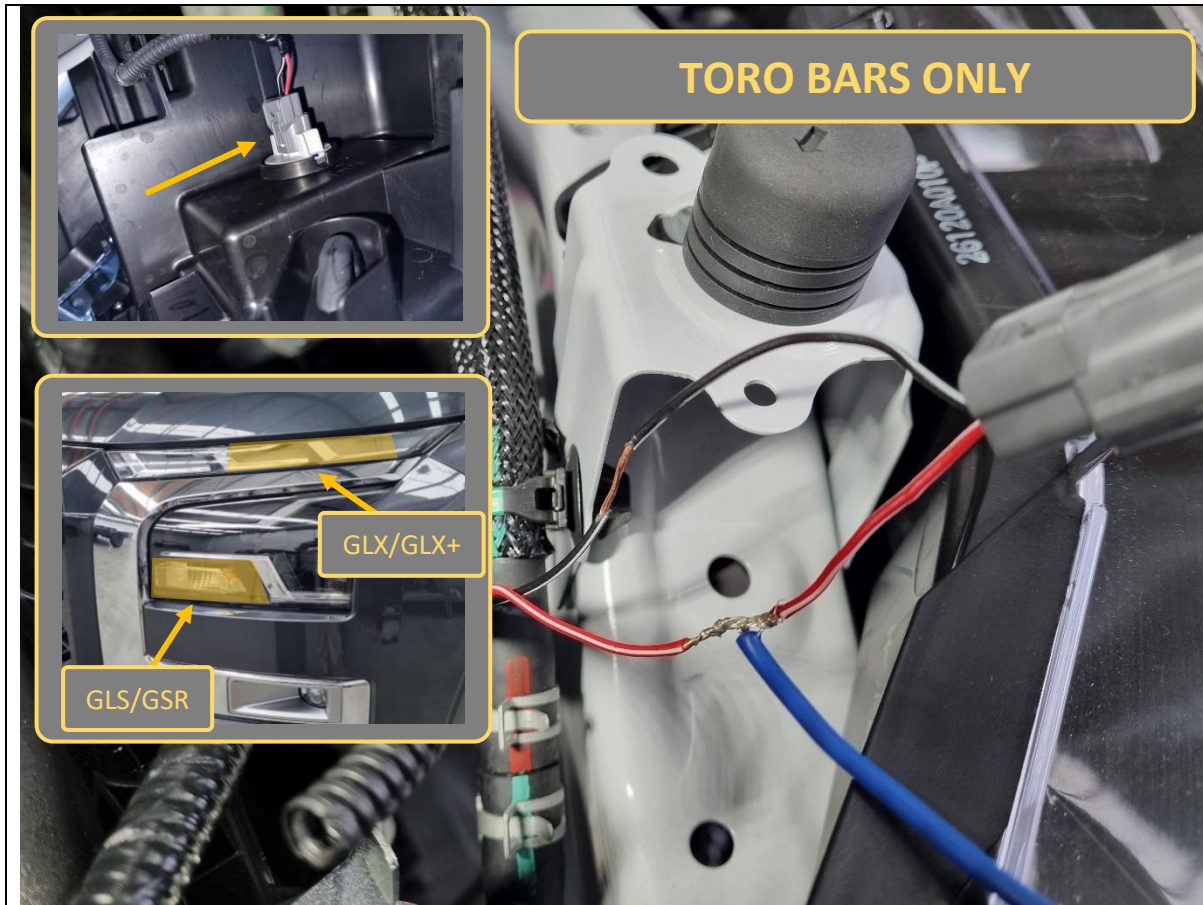

**TORO BARS ONLY**

77. Disconnect the plug behind the indicator bulb in the front headlight. Unclip the indicator harness from the back of the headlight for better access. (see inset photo for indicator location)
78. Probe with a test light to confirm indicator signal and ground. On GLS/GSR trim levels, the wiring pinout is as follows:
  - RH driver side:
    - red w/ white trace = indicator signal
    - black w/ white trace = ground
  - LH passenger side:
    - yellow w/white trace = indicator signal
    - black w/ white trace = ground
79. Splice and solder automotive electrical wires into the harness for indicator signal and ground. Use heat shrink or electrical tape to insulate solder connections. Do this for both LH and RH indicators.

- TOOLS REQUIRED**
- Cutting pliers
  - Wire strippers
  - Soldering iron
  - Solder
  - Automotive electrical wire
  - Heat shrink
  - Heat gun
  - Electrical tape

- FASTENERS**



80. If fitting an integrated light bar, do so now.

This bar is designed to fit the Offroad Animal 32-inch light bar. If fitting this light bar, assemble the light bar with legs facing inwards, and line it up with the slots in the centre gusset. Secure with M6 fasteners supplied with the light.

This bar can accommodate most other “30-32inch” size single row light bars. Stedi ST3K light bars require legs facing outwards.

81. If fitting driving lights, stealth hoop, round hoop or rally hoop to this bar, this is also the most convenient time to do so. It is still possible later but is more difficult.

**TOOLS REQUIRED**

Supplied with accessories

**FASTENERS**

Supplied with accessories

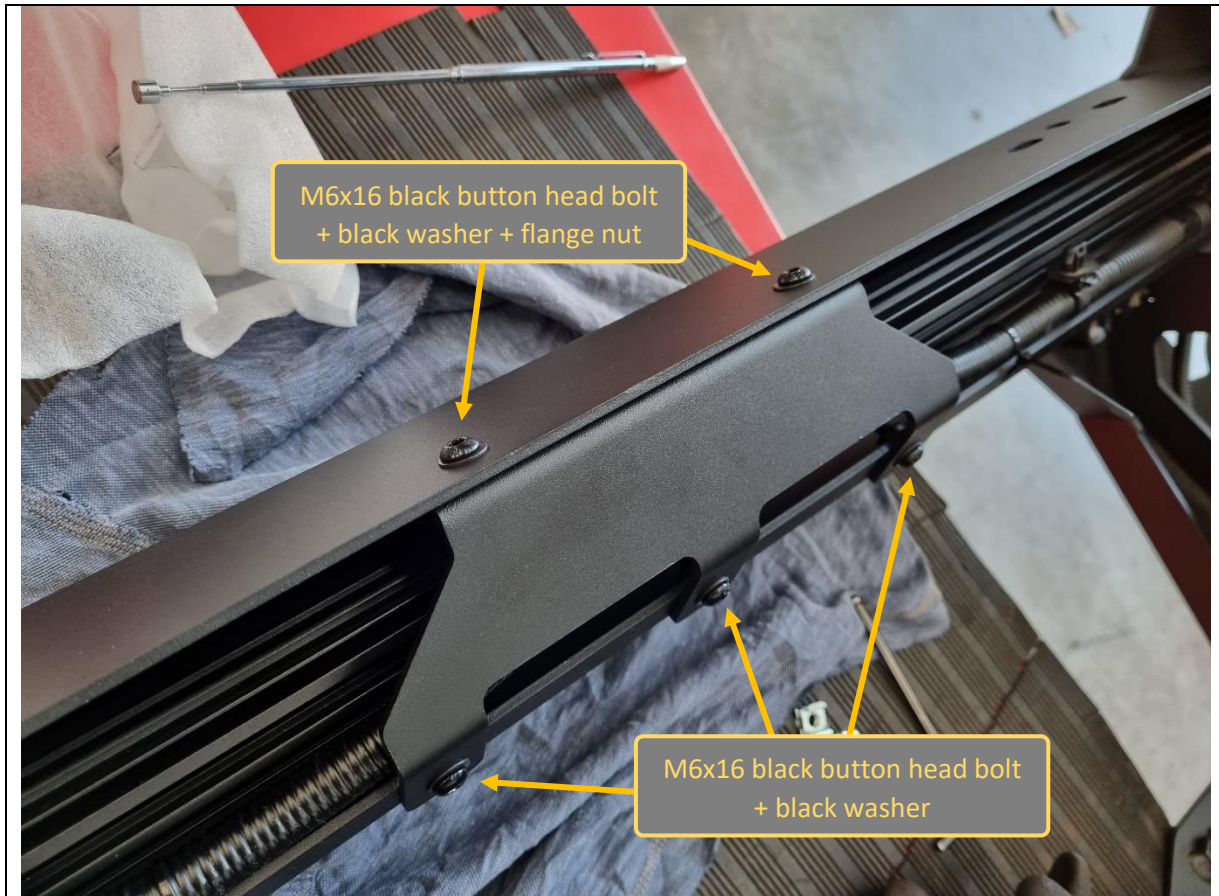

- 82. Temporarily unplug and disconnect the ICA radars and fog lights, then route the bumper wiring harness through the inside of the bullbar.
- 83. Fit the pan brace behind the top pan of the bullbar with M6x16 black button head bolts, with the wiring harness routed inside.

**TOOLS REQUIRED**

4mm hex/Allen key

**FASTENERS**

5x M6x16 black button head bolts  
5x M6 black flat washers  
2x M6 flange nuts





- 84. Temporarily unplug and disconnect the ICA radars and fog lights, then route the bumper wiring harness through the inside of the bullbar.
- 85. Fit the fog lights to the supplied fog light brackets with M6x16 black button head bolts. Note there are 2 versions of fog light bracket. Use the one with the correct hole pattern (3-bolt for GLS/GSR or 4-bolt for GLX/GLX+).

**TOOLS REQUIRED**

4mm hex/Allen key

**FASTENERS**

M6x16 black button head bolts  
M6 black flat washers  
M6 flange nuts



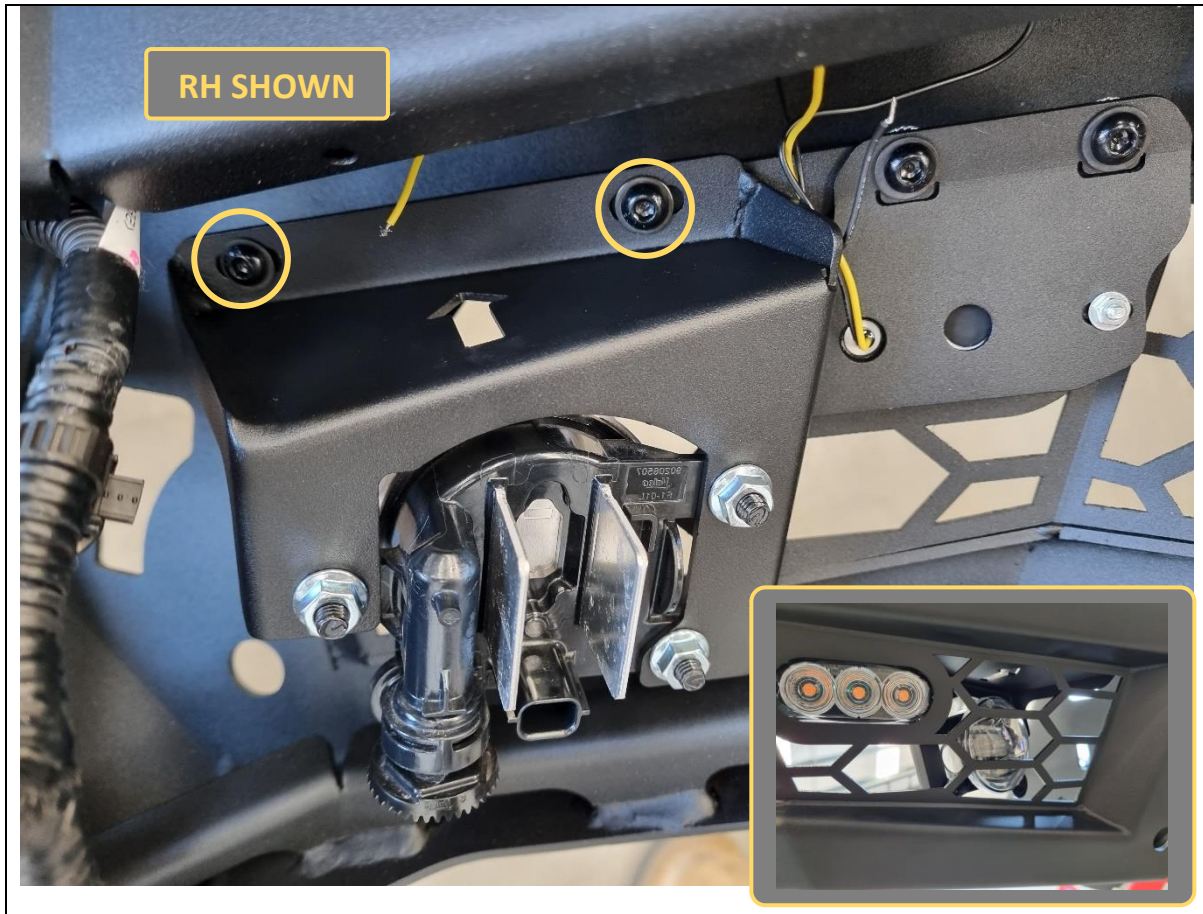

86. Fit the fog lights and brackets to the bullbar using 2x M16x16 black button head bolts, 2x black flat washers and 2x flange nuts each.

Note the arrow cutout in the bracket should be facing straight forward to direction of travel.

87. Reconnect the fog lights to the bumper harness.

**TOOLS REQUIRED**

4mm hex/Allen key

**FASTENERS**

4x M6x16 black button head bolts  
4x M6 black flat washers  
4x M6 flange nuts

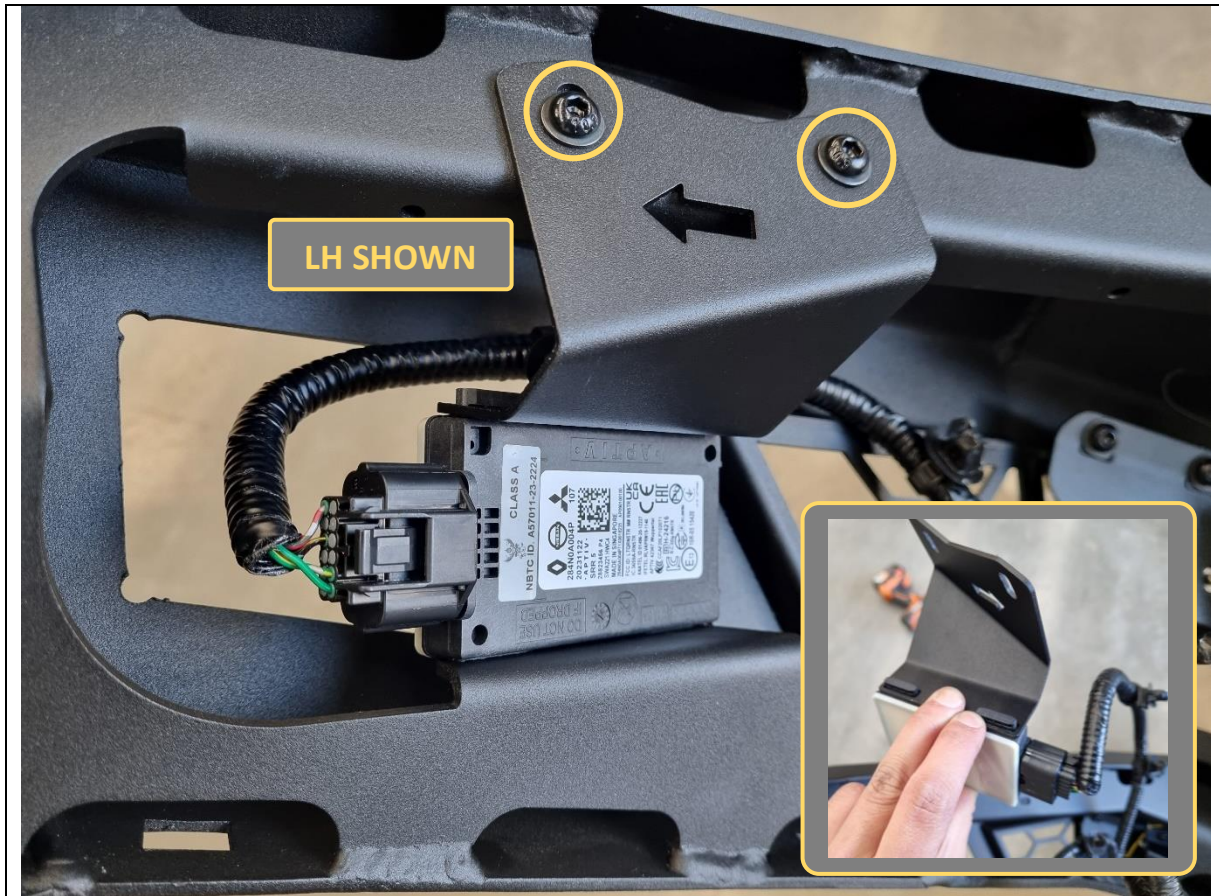

- 88. Fit the ICA radar into the slots in the side radar bracket, then fit into the side of the bullbar. The arrow cutout in the bracket should be pointing to the outer tip of the bullbar as well as the radar plug.
- 89. Apply firm pressure by hand to clamp the radar down in the bullbar, then secure the bracket with 2x M6x16 black button head bolts, washers and flange nuts. Ensure the radar does not rattle around. Loosen bolts and clamp further if required.
- 90. Repeat for other side.

**TOOLS REQUIRED**

4mm hex/Allen key

**FASTENERS**

4x M6x16 black button head bolts  
4x M6 black flat washers  
4x M6 flange nuts



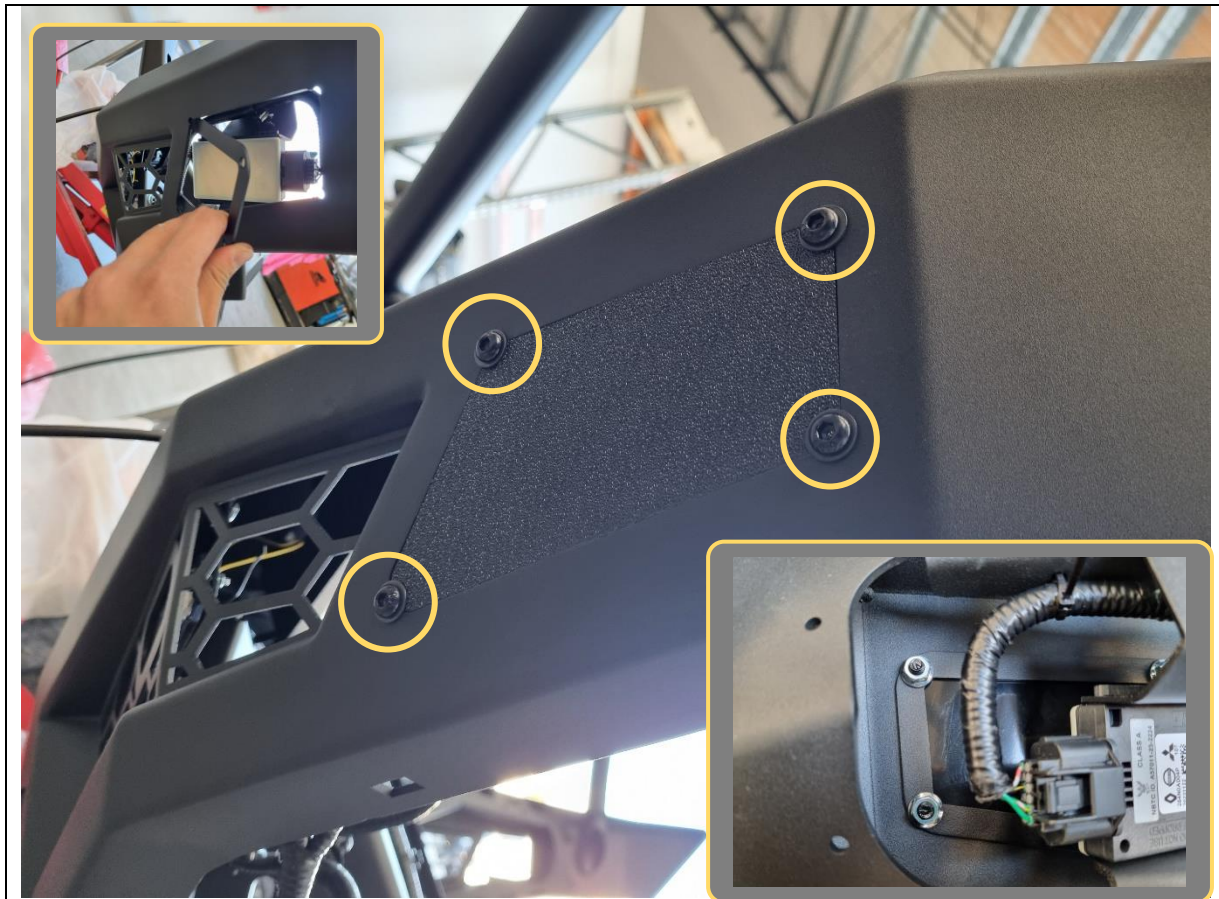

- 91. Insert the side radar cover mount plate through the open window in the bullbar (top left inset).
- 92. Fit the plastic radar cover panel (textured face on outside) to the bullbar and secure to the mount plate with 4x M6x16 black button head bolts, washers and flange nuts.
- 93. Repeat for other side.

**TOOLS REQUIRED**

4mm hex/Allen key

**FASTENERS**

8x M6x16 black button head bolts  
8x M6 black flat washers  
8x M6 flange nuts

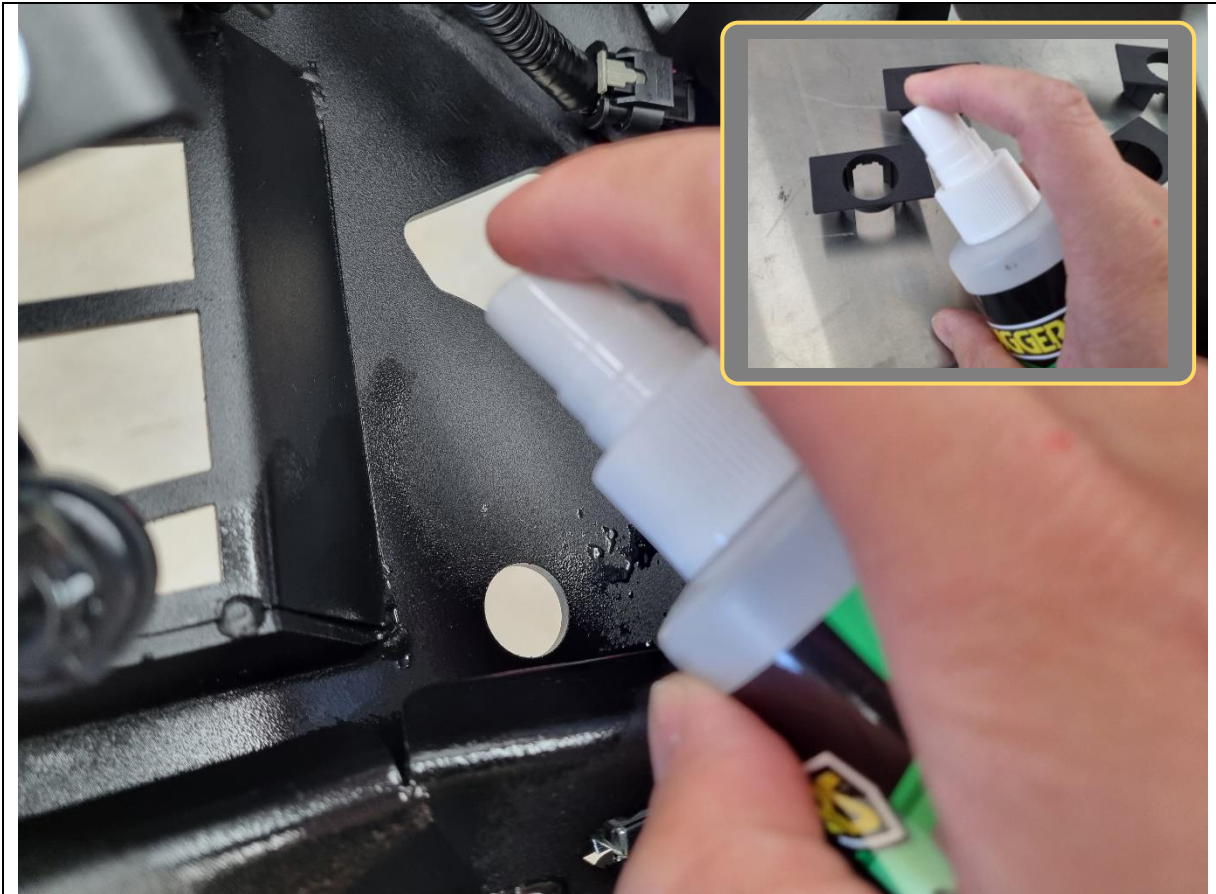

- 94. Clean the areas on the inside of the bullbar adjacent to the 4x round parking sensor holes with isopropyl alcohol.
- 95. Also clean the mounting faces of the 4x supplied plastic sensor holders with isopropyl alcohol.

**TOOLS REQUIRED**

- Isopropyl alcohol
- Clean rag

**FASTENERS**



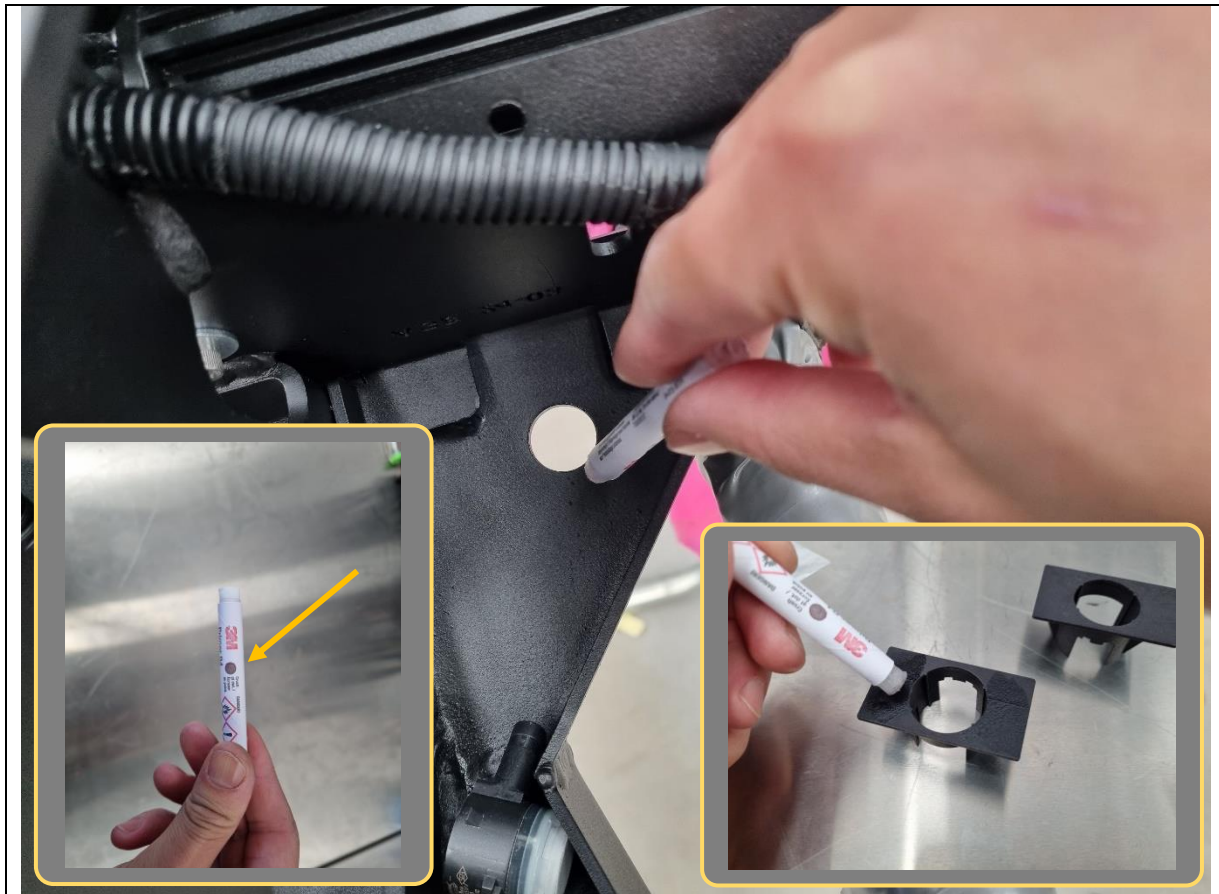

- 96. Press down on the arrow location and break the bulb of the supplied 3M Primer 94 ampule to activate the primer dispensing.
- 97. Apply 3M Primer 94 to all areas adjacent to the parking sensor locations, on both the bullbar and the sensor housings.
- 98. **Important:** allow at least 5 minutes for the primer to chemically bond to the surfaces.

**TOOLS REQUIRED**

**FASTENERS**



- 99. Fit parking sensors into plastic sensor housings.
- 100. Apply supplied VHB tape pads to all sensor housings as shown.

**TOOLS REQUIRED**

**FASTENERS**



<p>101. Remove backing film on VHB tape (easier with knife to peel off) and adhere parking sensors in position in bar. Apply pressure for at least 10 seconds after positioning for best adhesion.</p> <p>Ensure the parking sensor orientation matches the original bumper. Inner 2x sensors should have plugs pointing outwards. Outer 2x sensors should have plugs pointing inwards.</p>	<p><b>TOOLS REQUIRED</b></p> <p>Utility knife</p> <p>Cable ties</p>
<p>102. Connect all parking sensors to the bumper harness.</p> <p>103. Tidy up harness inside the bullbar and use cable ties to hold in place.</p> <p>Ensure main harness connectors are routed through the opening in the bullbar (circled in image above).</p>	<p><b>FASTENERS</b></p>





104. Fit 10x M6 cage nuts into the rectangular slots on the bottom of the bar wing (5x per side).

To aid fitting, use a small flat blade screwdriver to push the edge of the cage nut to engage with the slot.

**TOOLS REQUIRED**

Flat blade screwdriver

**FASTENERS**

10x M6 cage nut



- 105. **Toro only.** Fit antenna brackets to Toro uprights using M8x20 black button head bolts and black washers.
  
- 106. **Optional.** Fit supplied pinch weld along the top edge of the bullbar (see inset). You may need to notch some sections of the pinch weld to get around welds/pan brace.

**TOOLS REQUIRED**

- 5mm hex/Allen key
  
- Side cutters

**FASTENERS**

- 4x M8x20 black button head bolts
  
- 4x M8 black flat washers



107. **GLS/GSR only.** Remove 2x Phillips pan head screws on the inside of the bumper, per side.

**TOOLS REQUIRED**

Phillips head screwdriver

**FASTENERS**

4x pan head screws



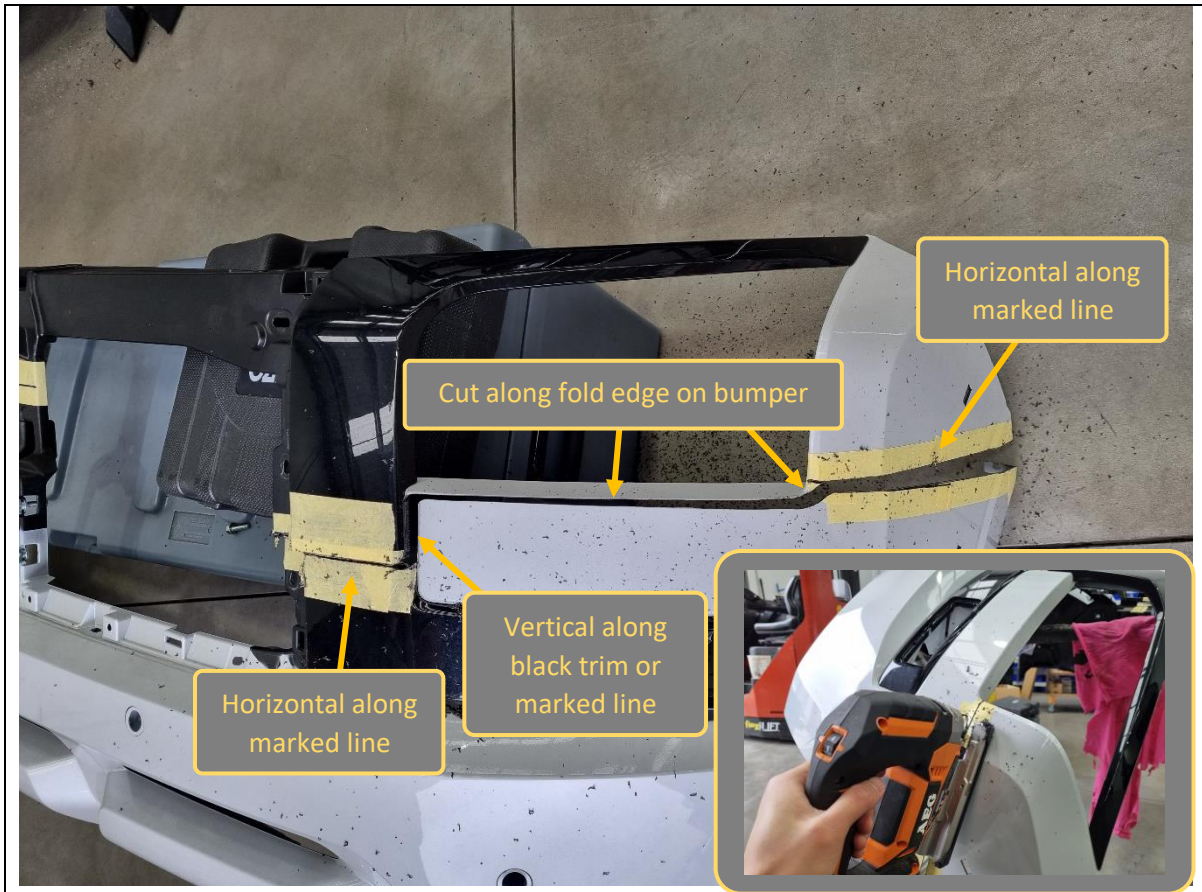

- 108. Support the bumper with assistance from either from another person or workshop equipment. This is important otherwise the bumper may buckle during trimming.
- 109. Cut the outer ends of the bumper as shown, following previously marked out lines.

**TOOLS REQUIRED**

Jigsaw  
or  
Air hacksaw  
or  
Multi-tool  
or  
Angle grinder

**FASTENERS**



- 110. Cut the middle section at the location shown.
- 111. Discard lower half of bumper.
- 112. Remove remaining masking tape and clean up cut edges with a knife or deburring tool.

**TOOLS REQUIRED**

- Jigsaw  
or  
Air hacksaw  
or  
Multi-tool  
or  
Angle grinder
- Deburring tool  
or  
Utility knife

**FASTENERS**



113. Re-fit the trimmed bumper to the vehicle.

114. Re-secure to the car with the 2x factory 10mm hex bolts removed from Step 32.

**TOOLS REQUIRED**

10mm socket/spanner

**FASTENERS**

2x factory 10mm hex bolts  
(retained from Step 32)





**GSR ONLY**

115. **GSR only.** Trim the flares.

It is suggested to take a conservative cut first and dry fit it to the vehicle to check fitment with the trimmed bumper, re-trimming if necessary, until the bottom edge of the trimmed flare lines up with the bumper and quarter panel.

Deburr/clean up the cut edges at the end.

**TOOLS REQUIRED**

Jigsaw  
or  
Air hacksaw  
or  
Multi-tool  
or  
Angle grinder

Deburring tool  
or  
Utility knife

**FASTENERS**



116. **GSR only.** Re-fit the trimmed flares and re-secure with fasteners/clips removed in Steps 17 and 18.

**TOOLS REQUIRED**

10mm socket/spanner

**FASTENERS**

6x factory 10mm hex bolts  
(retained from Step 17)

6x plastic push clips  
(retained from Step 18)

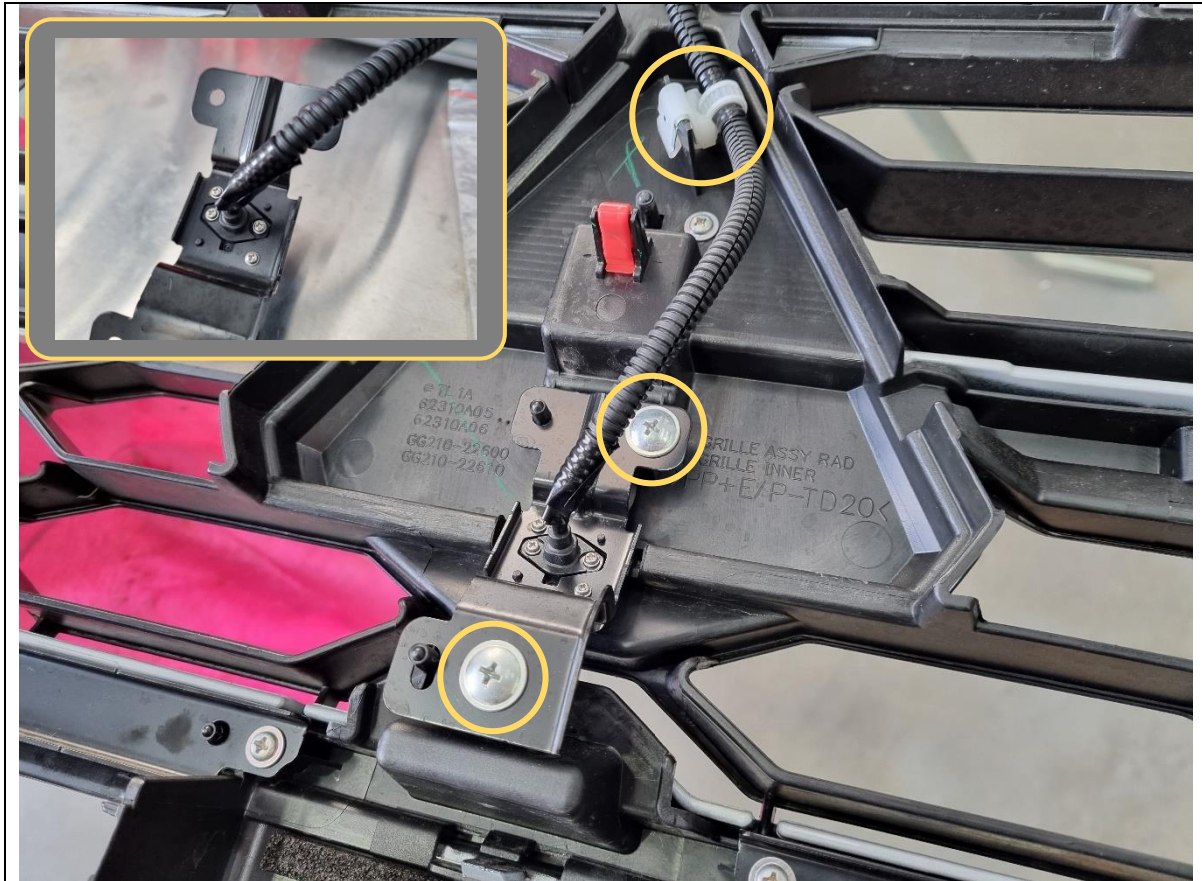

- 117. Remove the 2x Phillips pan head screws holding the camera bracket to the grille. Do not discard.
- 118. Unclip the camera and harness from the grille. Take note of camera orientation. The sticker label should be on top facing upwards.

**TOOLS REQUIRED**

Phillips head screwdriver

**FASTENERS**

2x pan head screws





119. Cut off the white loom clip on the camera harness.

120. Use a precision (jewellery) Phillips head screwdriver and undo the 2x tiny screws holding the camera on the bracket. Do not discard screws.

121. Separate the camera and harness from the bracket.

122. Re-fit the bracket back onto the grille, using the fasteners retained in Step 117.

**TOOLS REQUIRED**

Side cutters

Precision (jewellery) screwdriver

**FASTENERS**

2x pan head screws

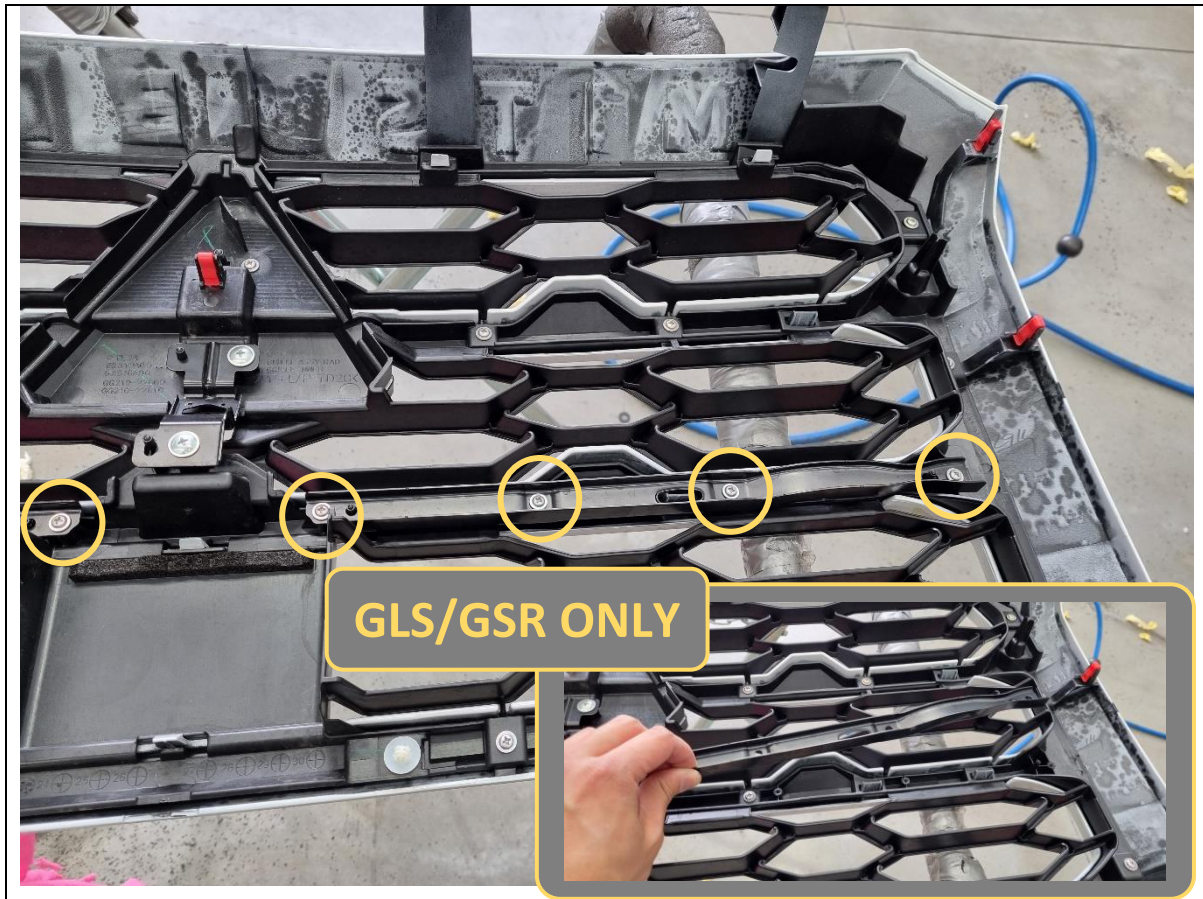

123. **GLS/GSR only.** Remove 8x Phillips pan head screws holding the 2x metal support brackets inside the grille and set aside. Do not discard.

**TOOLS REQUIRED**

Phillips head screwdriver

**FASTENERS**

10x pan head screws



124. **GLS/GSR only.** Trim the grille as shown, along the previously marked cut line, and below the horizontal plastic beam above the radar cover trim and mesh.

125. **GLS/GSR only.** Deburr/clean up trimmed edges.

**TOOLS REQUIRED**

Jigsaw  
or  
Air hacksaw  
or  
Multi-tool  
or  
Angle grinder

Deburring tool  
or  
Utility knife

**FASTENERS**



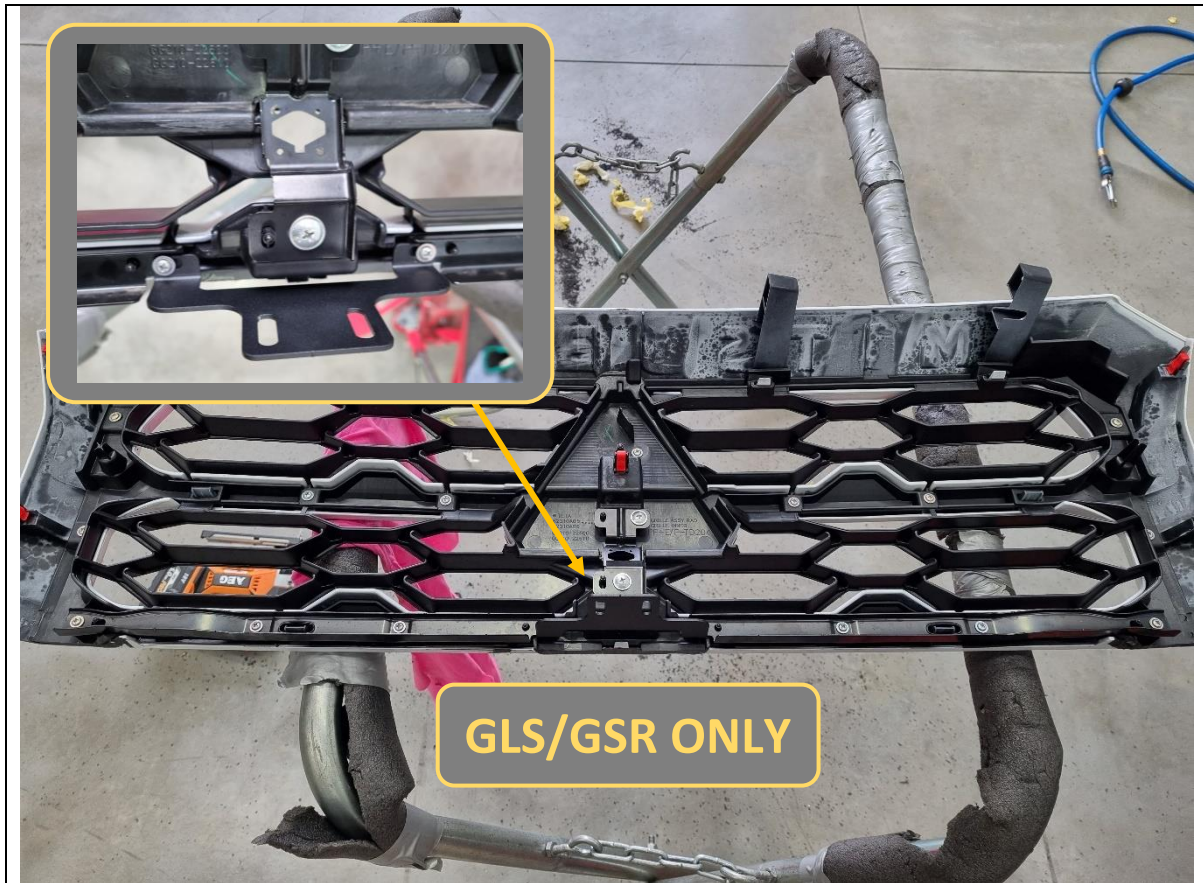

- 126. **GLS/GSR only.** Re-fit the 2x metal support brackets removed in Step 123.
- 127. **GLS/GSR only.** Fit B-1256 GLS/GSR Grille Support Bracket to the grille, using the same 2x middle screws from the metal support brackets (see inset).

**TOOLS REQUIRED**

Phillips head screwdriver

**FASTENERS**

8x pan head screws



128. **GLX/GLX+ only.** Trim the grille as shown.

129. **GLX/GLX+ only.** Deburr/clean up trimmed edges.

**TOOLS REQUIRED**

Jigsaw  
or  
Air hacksaw  
or  
Multi-tool  
or  
Angle grinder

Deburring tool  
or  
Utility knife

**FASTENERS**

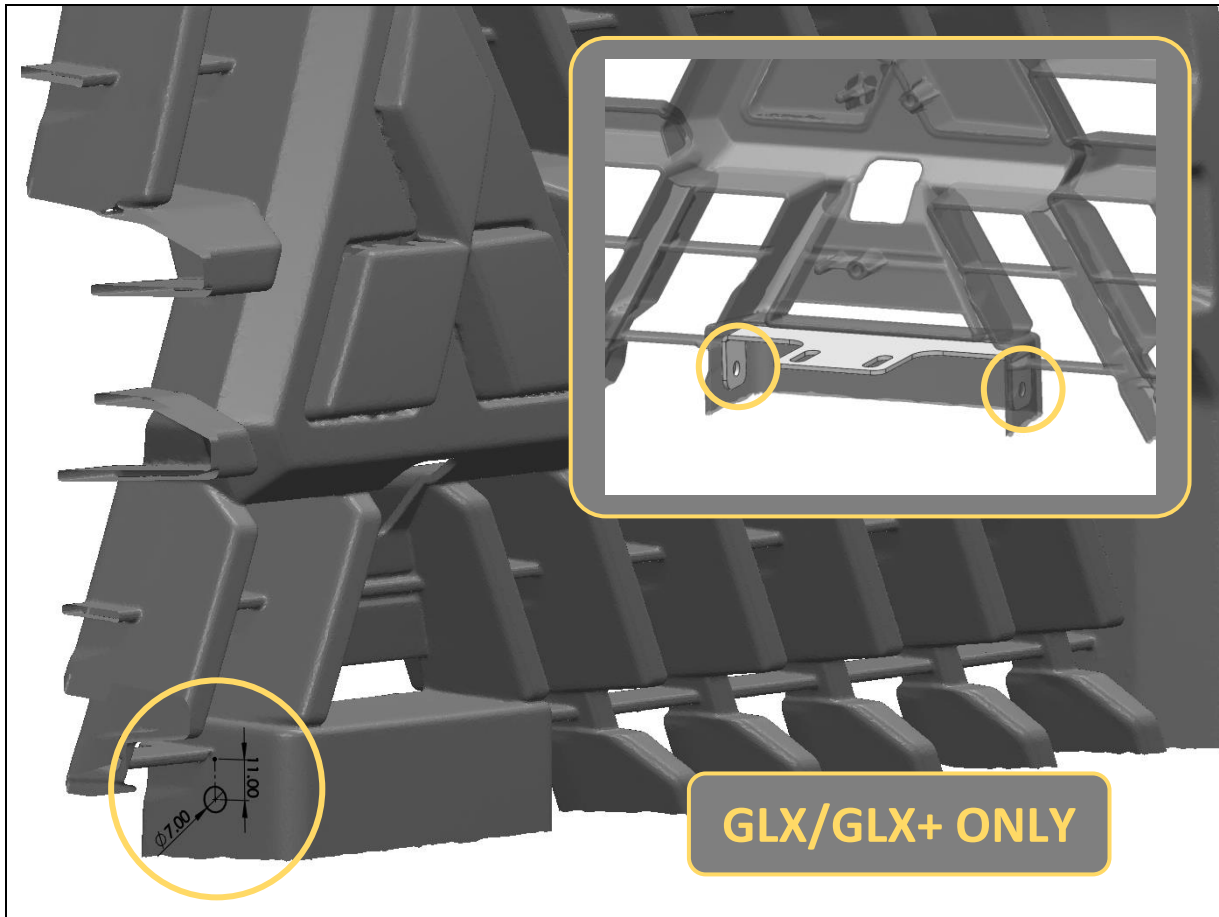

<p>130. <b>GLX/GLX+ only.</b> Mark points either side of the radar cover box section, 11mm vertically down from the point of the mesh vane.</p>	<p><b>TOOLS REQUIRED</b></p> <p>Ruler</p> <p>7mm drill bit</p> <p>Electric drill</p> <p>4mm hex/Allen key</p>
<p>131. <b>GLX/GLX+ only.</b> Check holes are marked correctly by test fitting B-1301 GLX/GLX+ Grille Support Bracket to the back of the grille and lining up the holes.</p> <p>132. <b>GLX/GLX+ only.</b> Drill a 7mm hole through the plastic on both sides.</p> <p>133. <b>GLX/GLX+ only.</b> Bolt the B-1301 grille support bracket to the back of the grille and secure with 2x M6x16 black button head bolts, black washers and flange nuts. Nuts are on inside.</p>	<p><b>FASTENERS</b></p> <p>2x M6x16 black button head bolts</p> <p>2x M6 black flat washers</p> <p>2x M6 flange nuts</p>





- 134. Re-fit the grille to the vehicle. Secure the top with the 2x plastic push clips removed in Step 12.
- 135. Secure the bottom grille bracket to the grille brace bracket (see Step 67) with 2x M6x16 black button head bolts, black washers and flange nuts.

**TOOLS REQUIRED**

4mm hex/Allen key

**FASTENERS**

2x Plastic Push Clips (see Step 12)  
 2x M6x16 black button head bolts  
 2x M6 black flat washers  
 2x M6 flange nuts



<p>136. With assistance, either from another person, or a lifting trolley, lift the bar onto the mounts on the vehicle.</p> <p>137. Reconnect the 2x bumper harness connectors to the vehicle, behind the grille.</p> <p>138. <b>Toro only.</b> Connect the indicator repeater lamps (solder/crimp together, ensure well insulated).</p>	<p><b>TOOLS REQUIRED</b></p> <p>Lifting trolley</p>
<p>139. Secure the bar to the mounts with 8x M12x30 Bolts, heavy duty washers and M12 Nyloc + flange nuts. Leave finger tight at this stage.</p> <p>Note: Use a washer on both bolt and nut side for the Nyloc nut. 1x washer on the bolt side is all that is required with flange nuts.</p>	<p><b>FASTENERS</b></p> <p>8x M12x30 hex bolt 10x M12 heavy duty washer 2x M12 Nyloc nut 6x M12 flange nut</p>



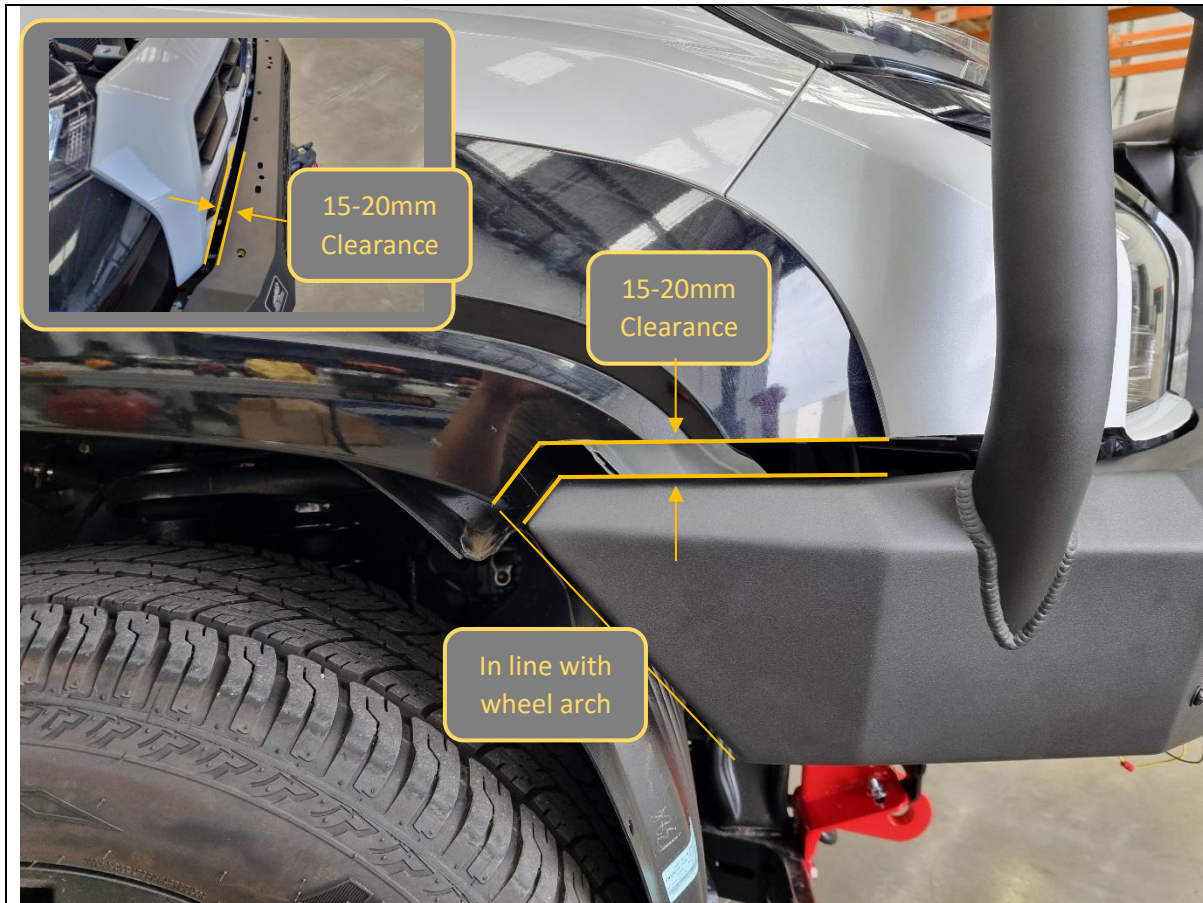

<p>140. With assistance, from another person, align the bar with the edges of the vehicle. The bar should sit symmetric left/right on the vehicle.</p> <p>Front view: the bar should sit horizontally level with the body.</p> <p>Side view: the bar should be 15-20mm vertical clearance to the trimmed bumper. The end of the bar wing should be in line with the wheel arch liner.</p> <p>Top view: there should be 15-20mm clearance between the bar and grille.</p>	<p><b>TOOLS REQUIRED</b></p> <p>18/19mm socket/spanner</p>
<p>141. Once happy with alignment, tighten all 8x M12 bolts.</p>	<p><b>FASTENERS</b></p>



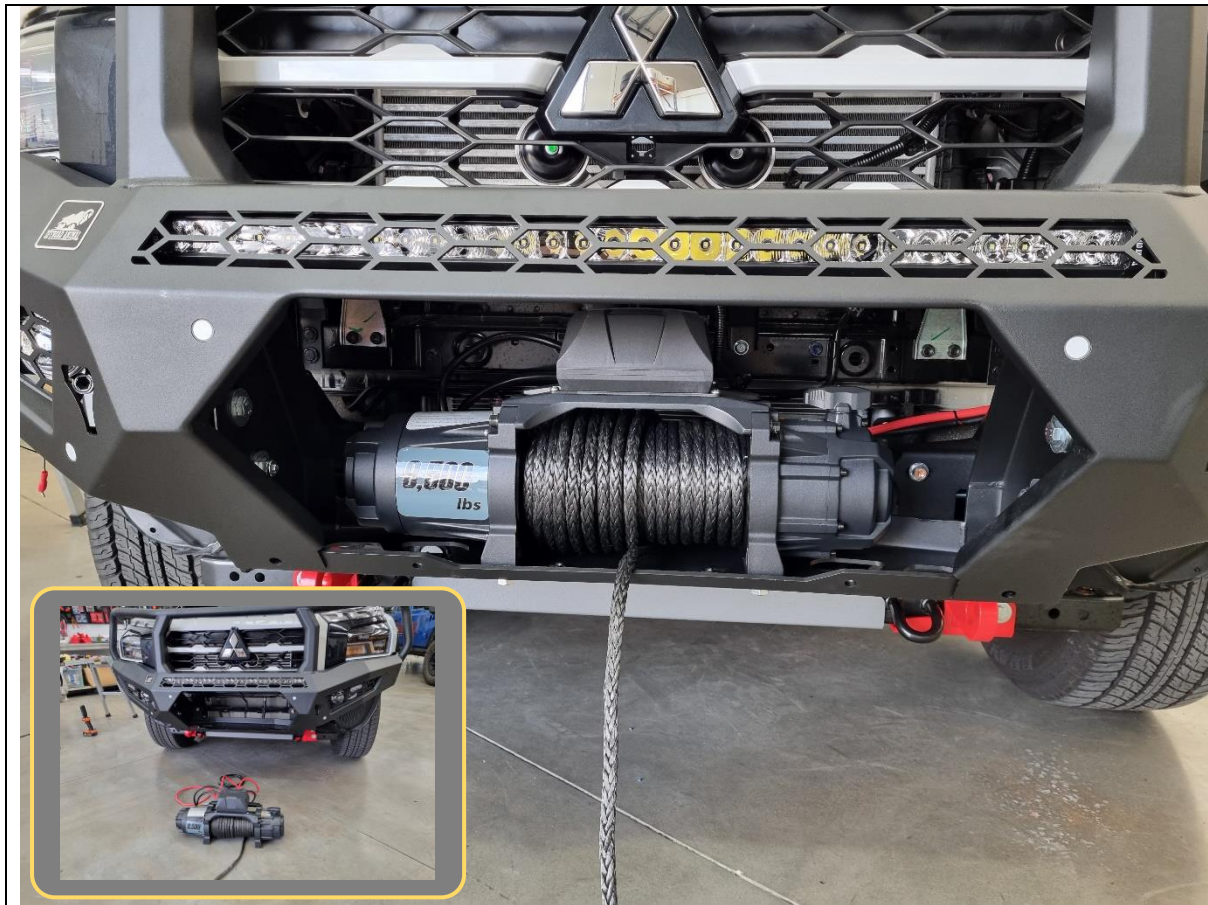

142. If fitting a winch, do so now.

143. This bar is designed to fit most low mount winches, in foot down configuration. WARN ZEON 12 is the largest winch confirmed to fit.

144. Ensure clutch handle will be accessible through opening in front mesh panel. Refer to winch instructions regarding changing clutch handle location.

**TOOLS REQUIRED**

Refer to instructions supplied by winch

**FASTENERS**

Supplied with winch

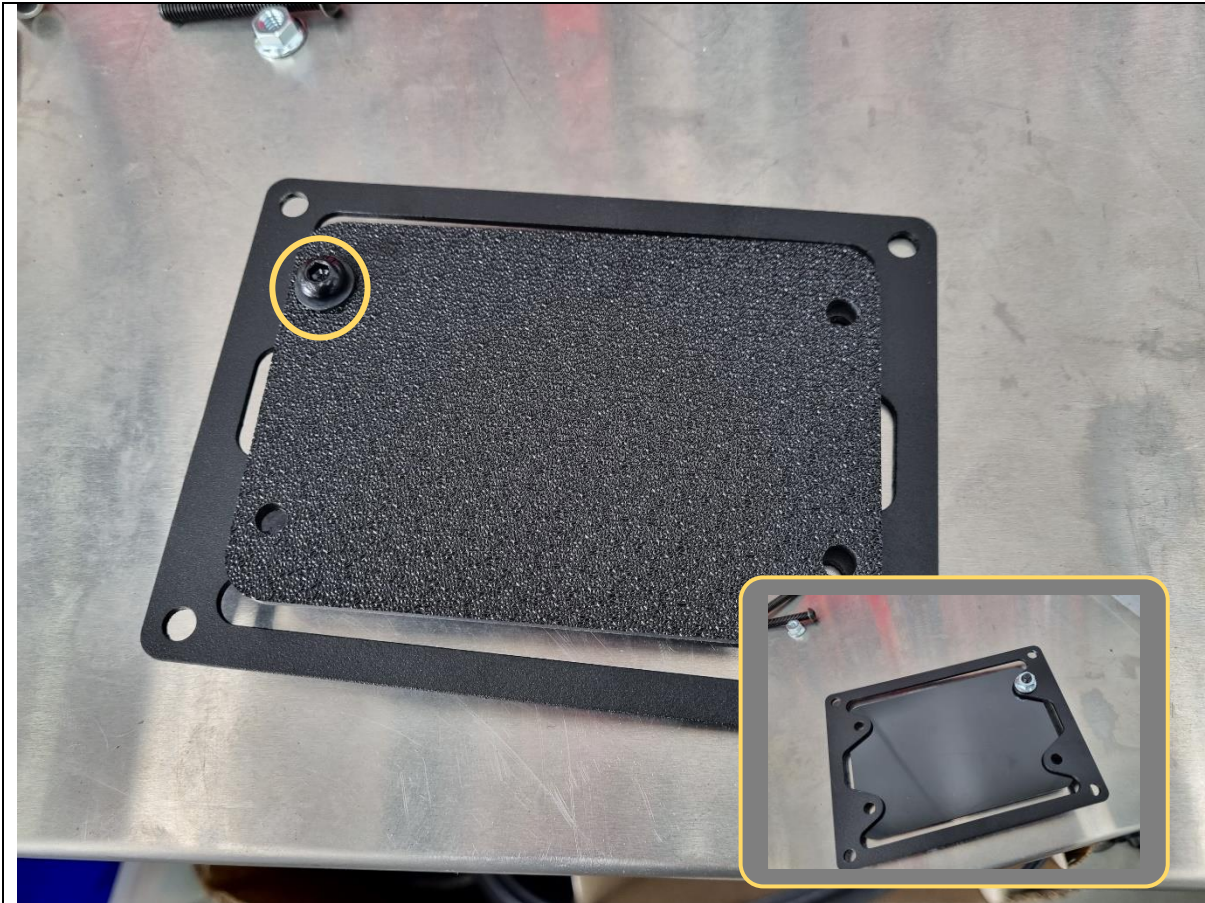

145. Fit the plastic ACC radar cover panel to the P-0381 radar mount plate and loosely secure with 1x M6x16 black button head bolt, black washer and flange nut in the top left corner.

The textured size of the plastic cover should be facing outwards.

**TOOLS REQUIRED**

**FASTENERS**

- 1x M6x16 black button head bolt
- 1x M6 black flat washer
- 1x M6 flange nut





- 146. Assemble 3x M6x45 black button head bolts, black flat washers, and T-0108 23mm crush tubes onto the radar mount (bottom left inset).
- 147. Secure the radar to the mount with 3x M6 flange nuts as shown. Plugs facing out the back away from the plastic cover.
- 148. Tighten all 4x M6 bolts.

**TOOLS REQUIRED**

4mm hex/Allen key

**FASTENERS**

3x M6x45 black button head bolts  
 3x M6 black flat washer  
 3x T-0108 23mm crush tube  
 3x M6 flange nut



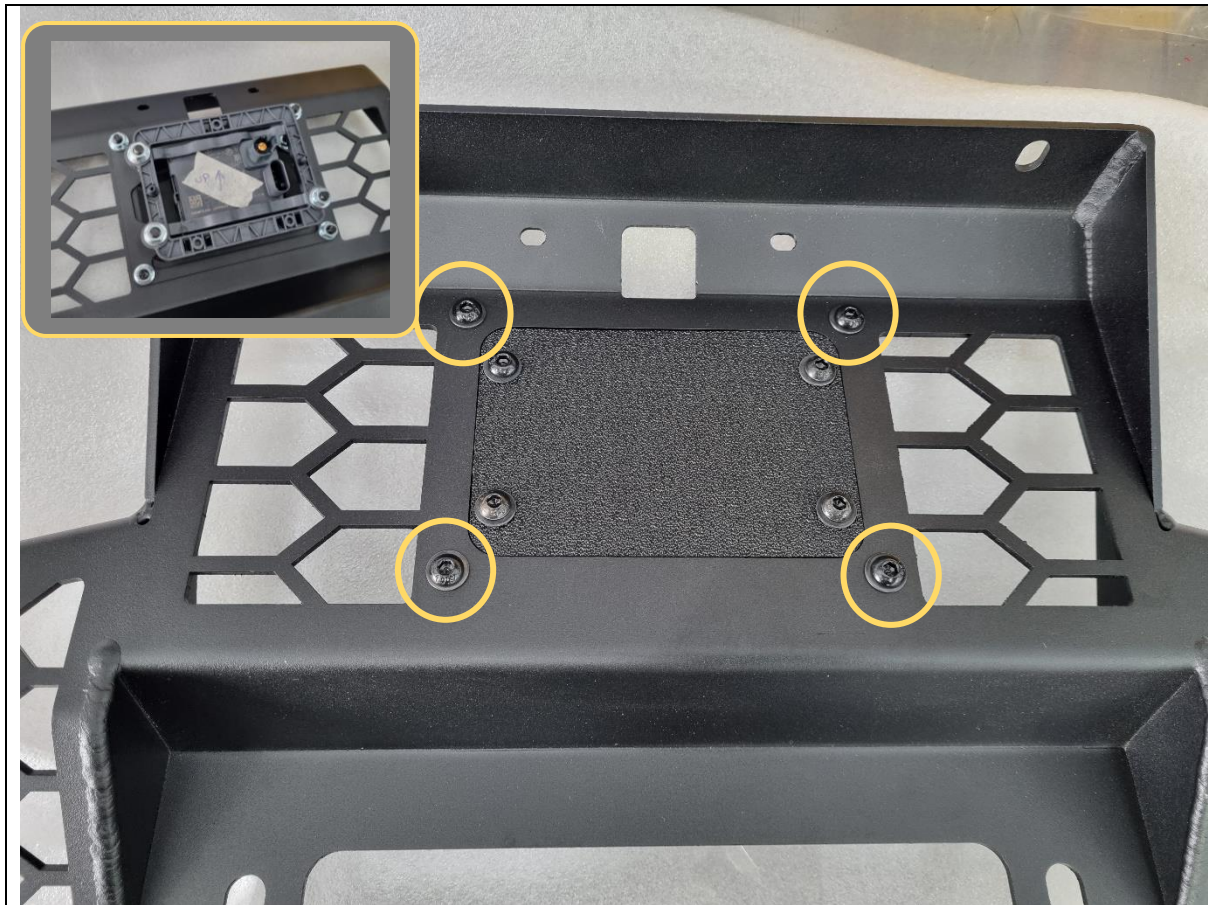

149. Fit the radar and mount through the open window in the mesh fairlead and secure with 4x M6x16 black button head bolts, black washers and flange nuts.

Ensure correct radar orientation is maintained from factory.

**TOOLS REQUIRED**

4mm hex/Allen key

**FASTENERS**

4x M6x16 black button head bolts  
4x M6 black flat washer  
4x M6 flange nut



150. Use a precision (jewellery) Phillips head screwdriver to secure the 2x tiny screws holding the camera to the front of the camera mount plate.

Ensure camera orientation is the same as in the photo.

**TOOLS REQUIRED**

Precision (jewellery) screwdriver

**FASTENERS**

2x pan head screws



- 151. Fit the camera and mount through the square cutout in the mesh fairlead.
- 152. Fit the camera cover onto the front of the mesh fairlead, then secure to the mount plate on the back with 2x M6x16 black button head bolts, black washers and flange nuts.

**TOOLS REQUIRED**

4mm hex/Allen key

**FASTENERS**

2x M6x16 black button head bolts  
2x M6 black flat washer  
2x M6 flange nut



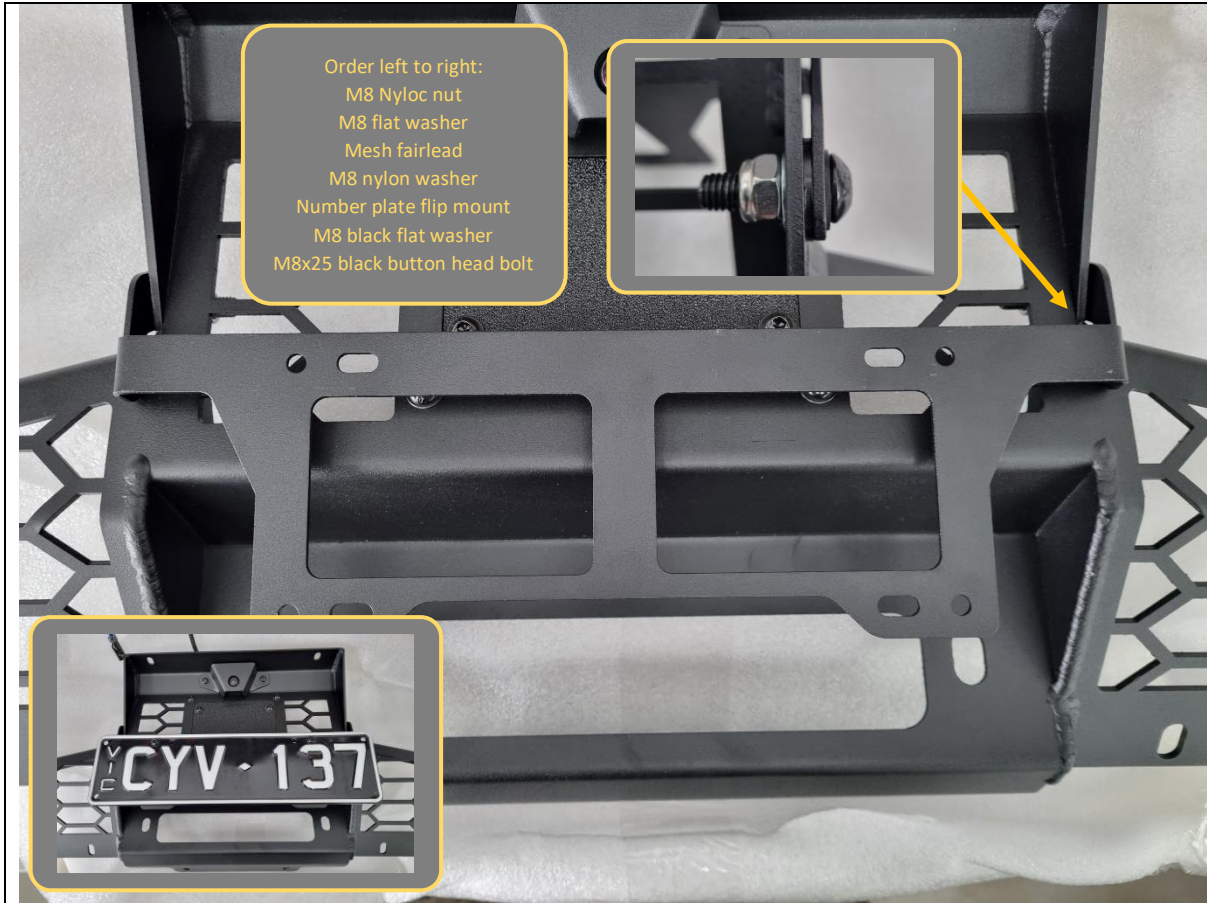

<p>153. Fit number plate flip mount to mesh panel as shown above. Tighten bolts so that flip mount and can be moved by hand with some friction resistance.</p> <p>154. Attach number plate to mount using 2x M6x16 black button head bolts, black washers and flange nuts.</p>	<p><b>TOOLS REQUIRED</b></p> <p>5mm hex/Allen key 13mm socket/spanner</p> <p>4mm hex/Allen key</p>
	<p><b>FASTENERS</b></p> <p>2x M8x25 black button head 2x M8 black flat washer 2x M8 nylon washer 2x M8 flat washer 2x M8 flange nut</p> <p>2x M6x16 black button head bolts 2x M6 black flat washer 2x M6 flange nut</p>



155. If required, fit the winch fairlead to the mesh fairlead mount using M10 or 3/8" fasteners supplied with the winch. This bar is only compatible with hawse type fairleads.

**TOOLS REQUIRED**

Refer to instructions supplied by winch

**FASTENERS**

Supplied with winch

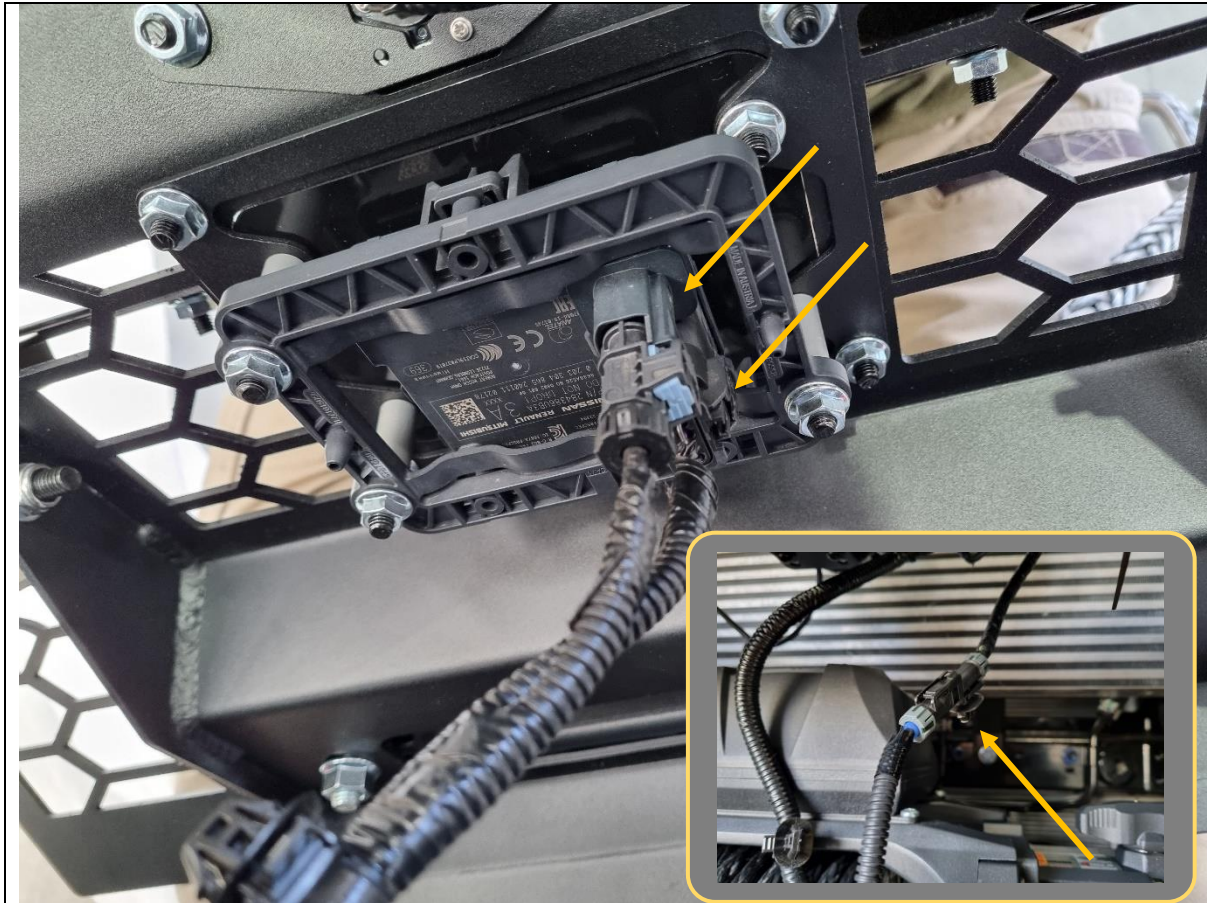

156. Hold the mesh fairlead mount up near the bar and reconnect the 2x radar harnesses and 1x camera harness.

**TOOLS REQUIRED**

**FASTENERS**



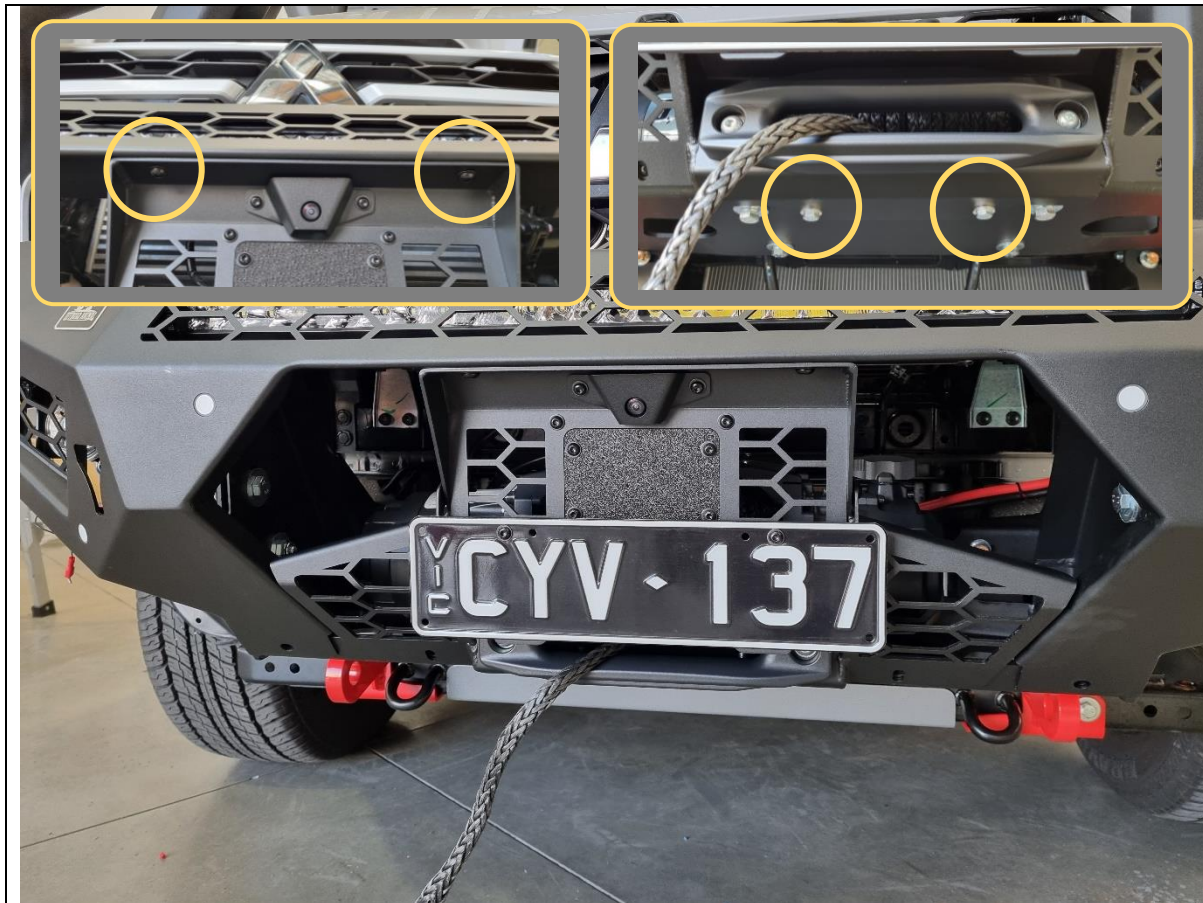

- 157. Fit the mesh fairlead mount to the centre of the bar, using 2x M8x16 black button head bolts + black washers (top), 2x M8x20 hex head bolts + heavy duty washers (bottom).
- 158. Tighten fasteners using 13mm socket/spanner and 5mm hex/Allen key.
- 159. Feed winch cable through the hawse fairlead if applicable.

**TOOLS REQUIRED**

- 13mm socket/spanner
- 5mm hex/Allen key

**FASTENERS**

- 2x M8x16 black button head
- 2x M8 black flat washer
- 2x M8x20 hex head
- 2x M8 heavy duty washer

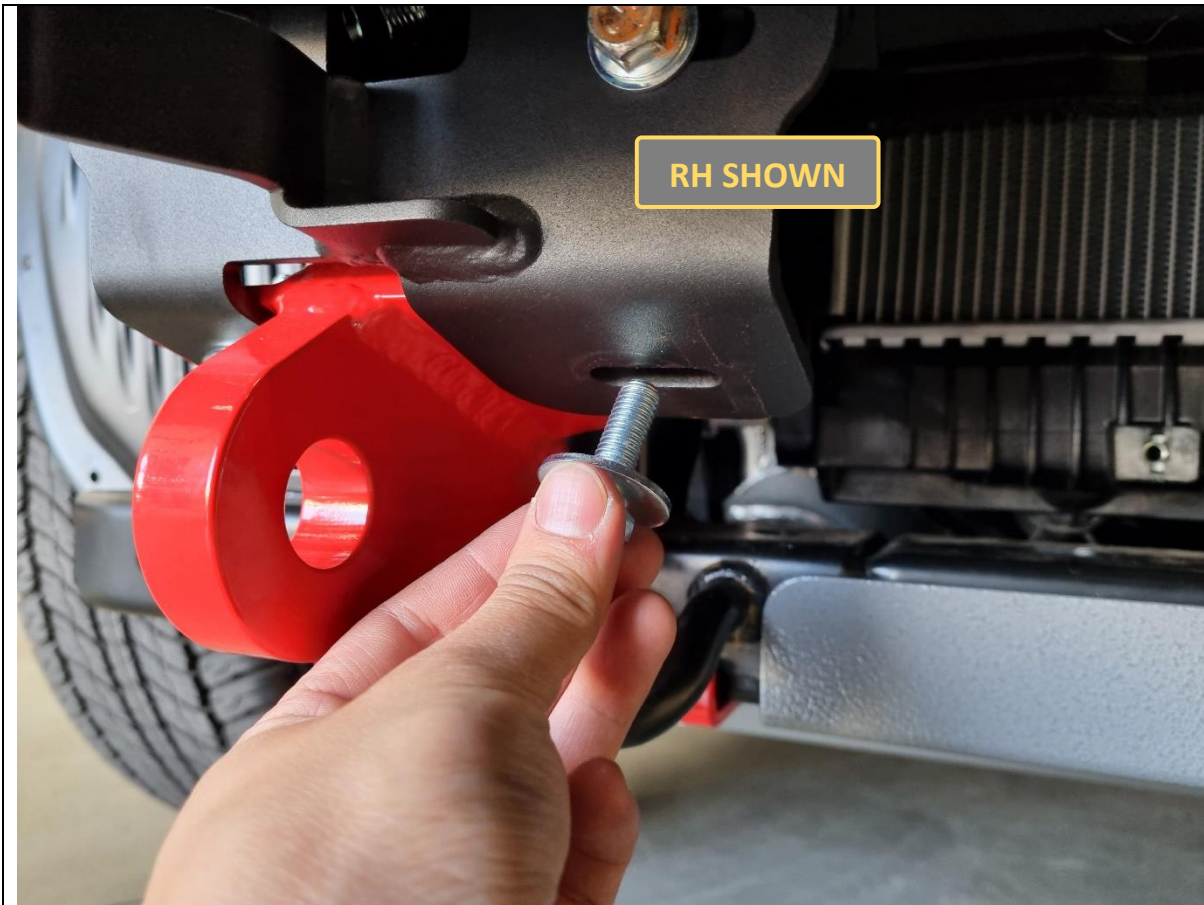

160. Loosen the lower inner M10x30 hex bolts on the impact assemblies in preparation for fitting main bash plate.

**TOOLS REQUIRED**

16/17mm socket/spanner

**FASTENERS**

2x M10x30 hex head bolt  
2x M10 heavy duty washer  
2x M10 flange nut

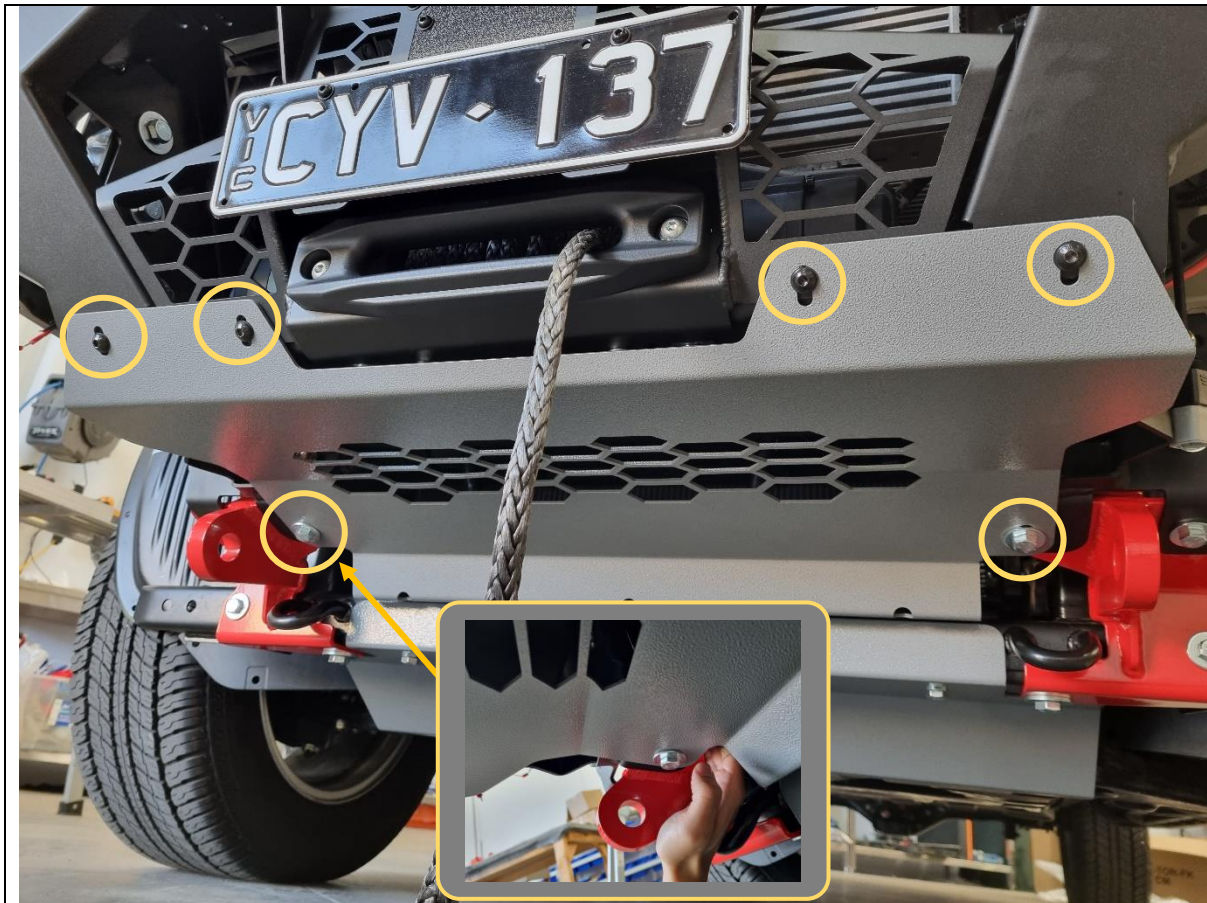

- 161. Fit the centre bash plate to the bar using 4x M8x25 black button bolts and flat washers.
- 162. Secure the back of the centre bash plate to the impact assemblies using 2x M10x30 hex head bolts, heavy duty washers and flange nuts.

**TOOLS REQUIRED**

- 5mm hex/Allen key
- 16/17mm socket/spanner

**FASTENERS**

- 4x M8x25 black button head
- 4x M8 black flat washer
- 2x M10x30 hex head bolt
- 2x M10 flat washer
- 2x M10 flange nut



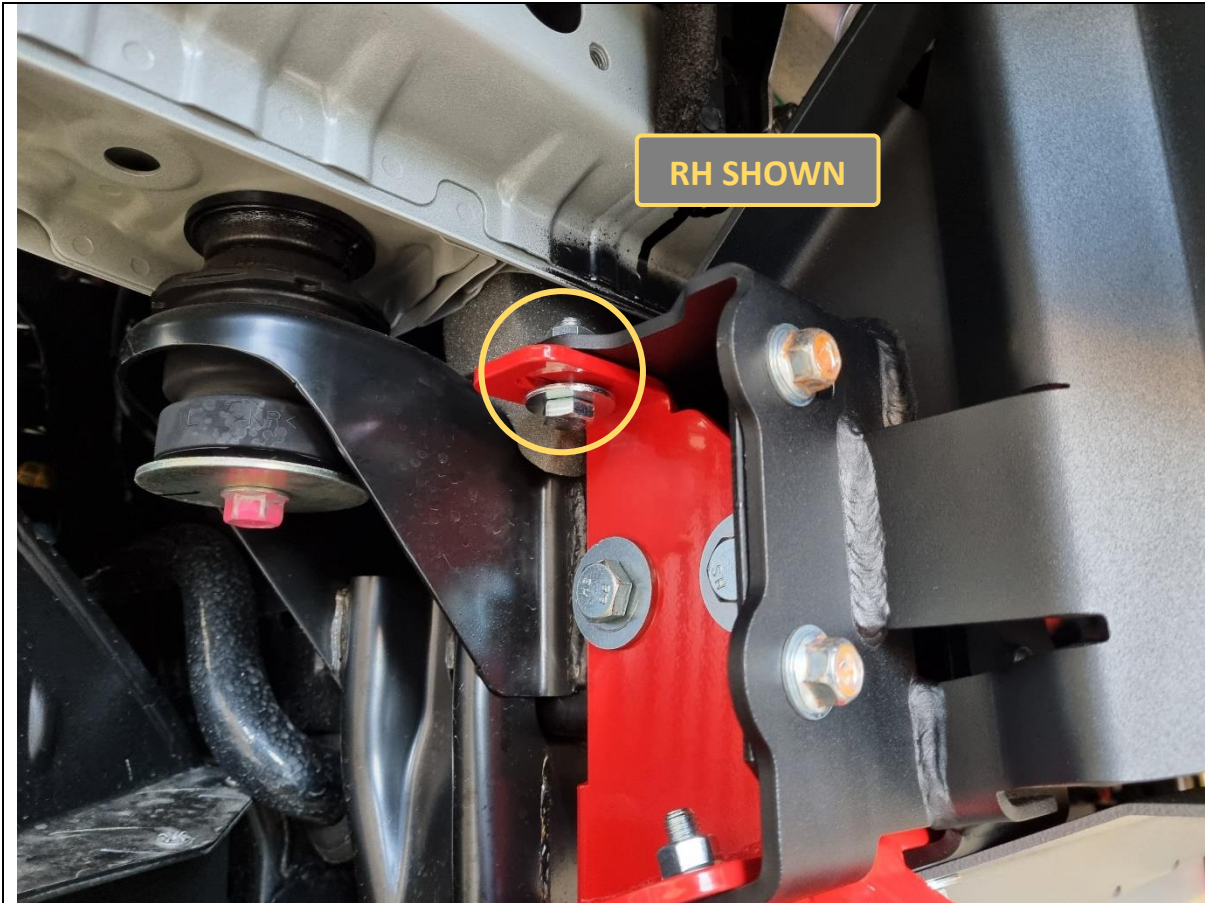

163. Loosen the upper rear M10x30 hex bolts on the impact assemblies in preparation for fitting side underpanels.

**TOOLS REQUIRED**

16/17mm socket/spanner

**FASTENERS**

2x M10x30 hex head bolt  
2x M10 heavy duty washer  
2x M10 flange nut

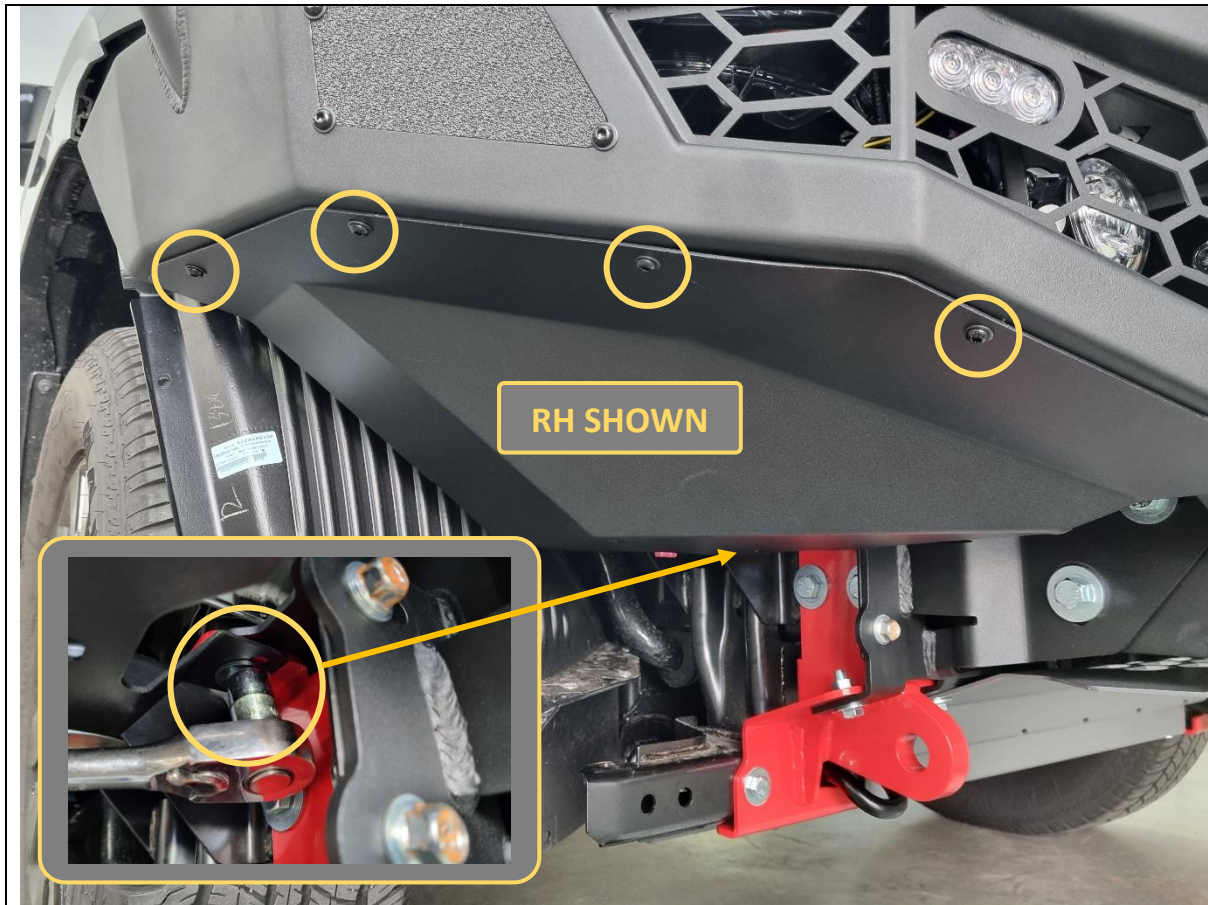

- 164. Loosely secure the side underpanel to the bar with 5x M6x16 black button head bolts and black flat washers.
- 165. Loosely secure the side underpanel to the impact assembly using 1x M10x30 hex head bolt, heavy duty washer and flange nut.
- 166. Repeat for other side underpanel.

**TOOLS REQUIRED**

4mm hex/Allen key

16/17mm socket/spanner

**FASTENERS**

10x M6x16 black button head  
10x M6 black flat washer

2x M10x30 hex head bolt  
2x M10 heavy duty washer  
2x M10 flange nut

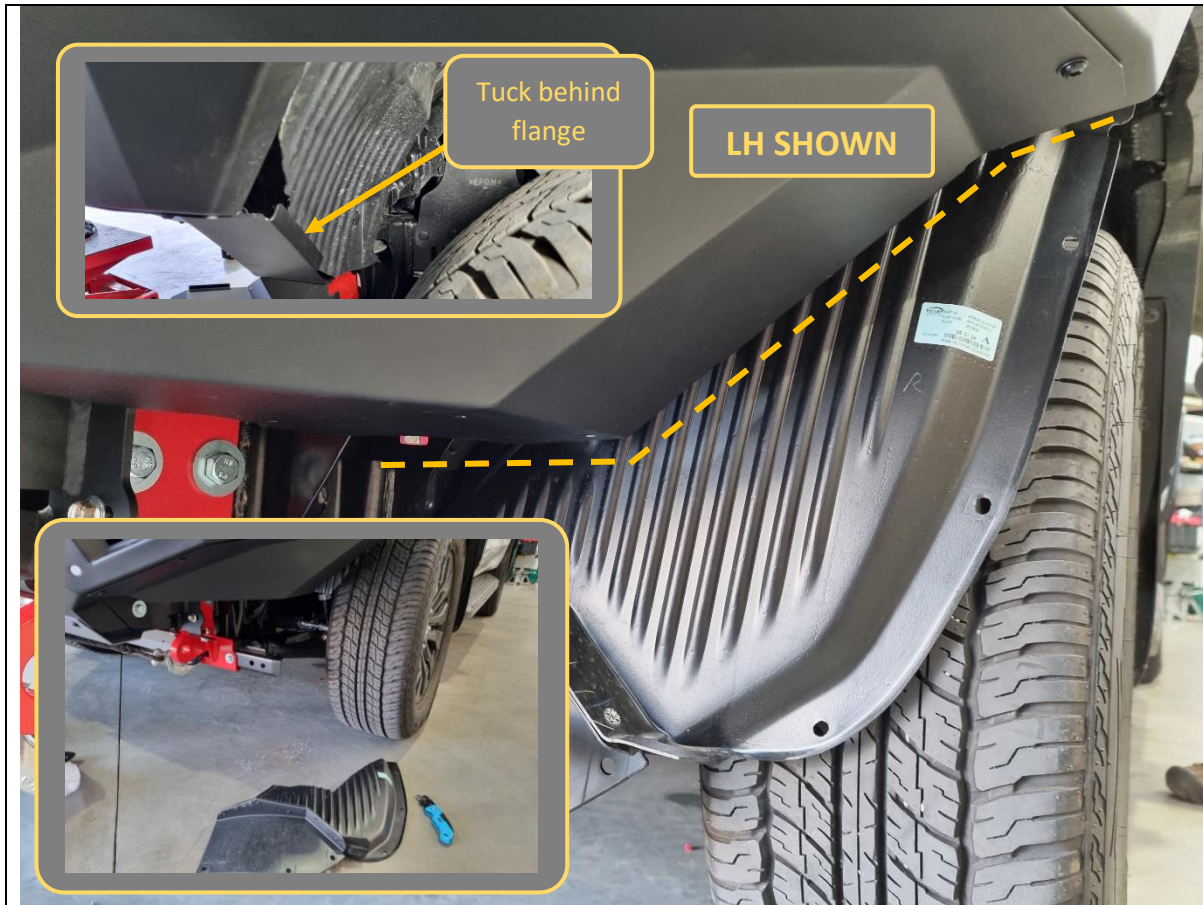

167. Using the edge of the side underpanel as a guide, mark the wheel arch liner, approximately 10mm below the side underpanel.
168. Cut along the marked line with a utility knife.
169. Tuck the wheel arch liner behind the flange of the side underpanel.
170. Tighten all side underpanel bolts and repeat for other side.

**TOOLS REQUIRED**

- Utility knife
- 4mm hex/Allen key
- 16/17mm socket/spanner

**FASTENERS**



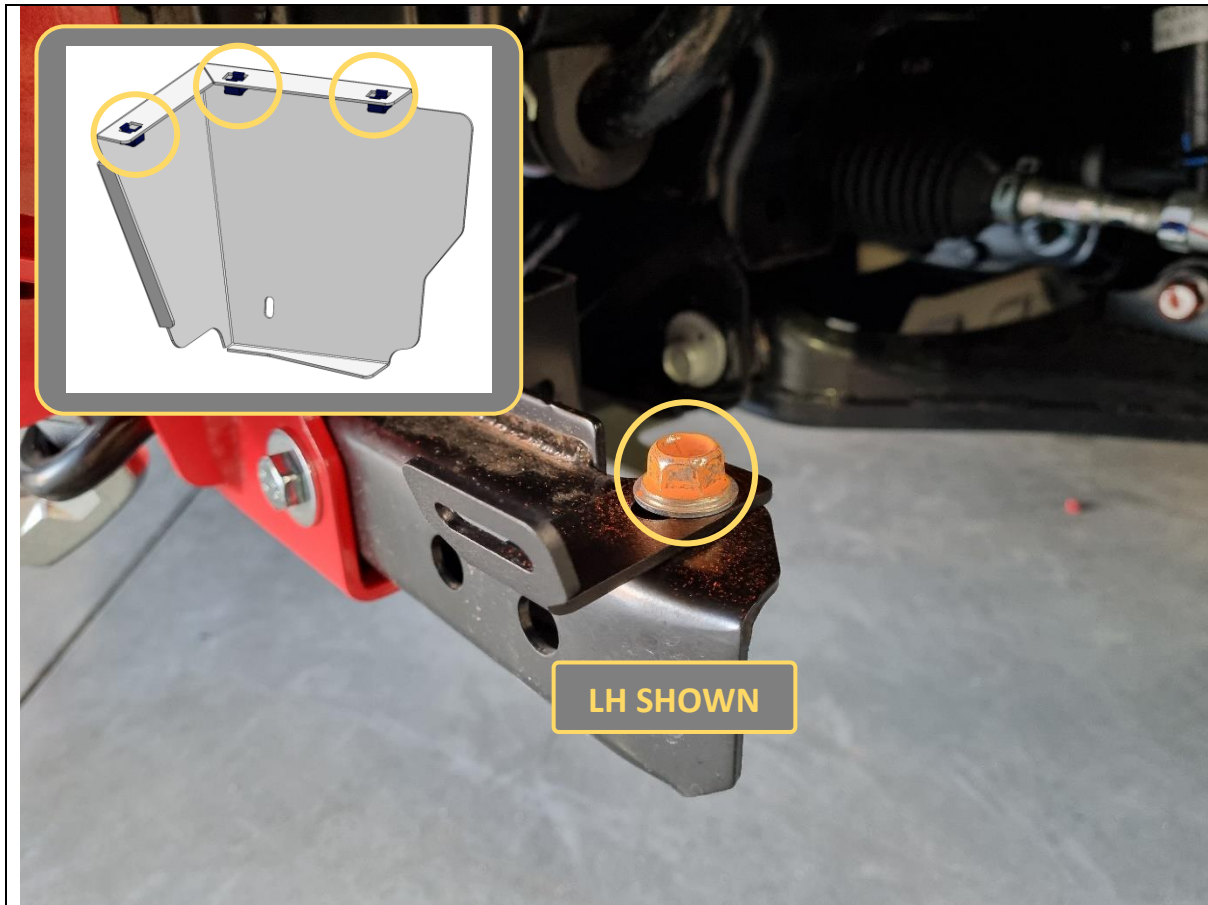

- 171. Loosely secure the B-1255 Lower Side Underpanel Mount to the chassis with 1x 14mm factory hex bolt retained from Step 41. Do this on both sides.
- 172. Fit 3x M6 cage nuts into the inside of both lower side underpanels with a flat blade screwdriver for assistance.

**TOOLS REQUIRED**

Flat blade screwdriver

**FASTENERS**

2x 14mm factory hex bolts  
(see Step 41)

6x M6 cage nuts

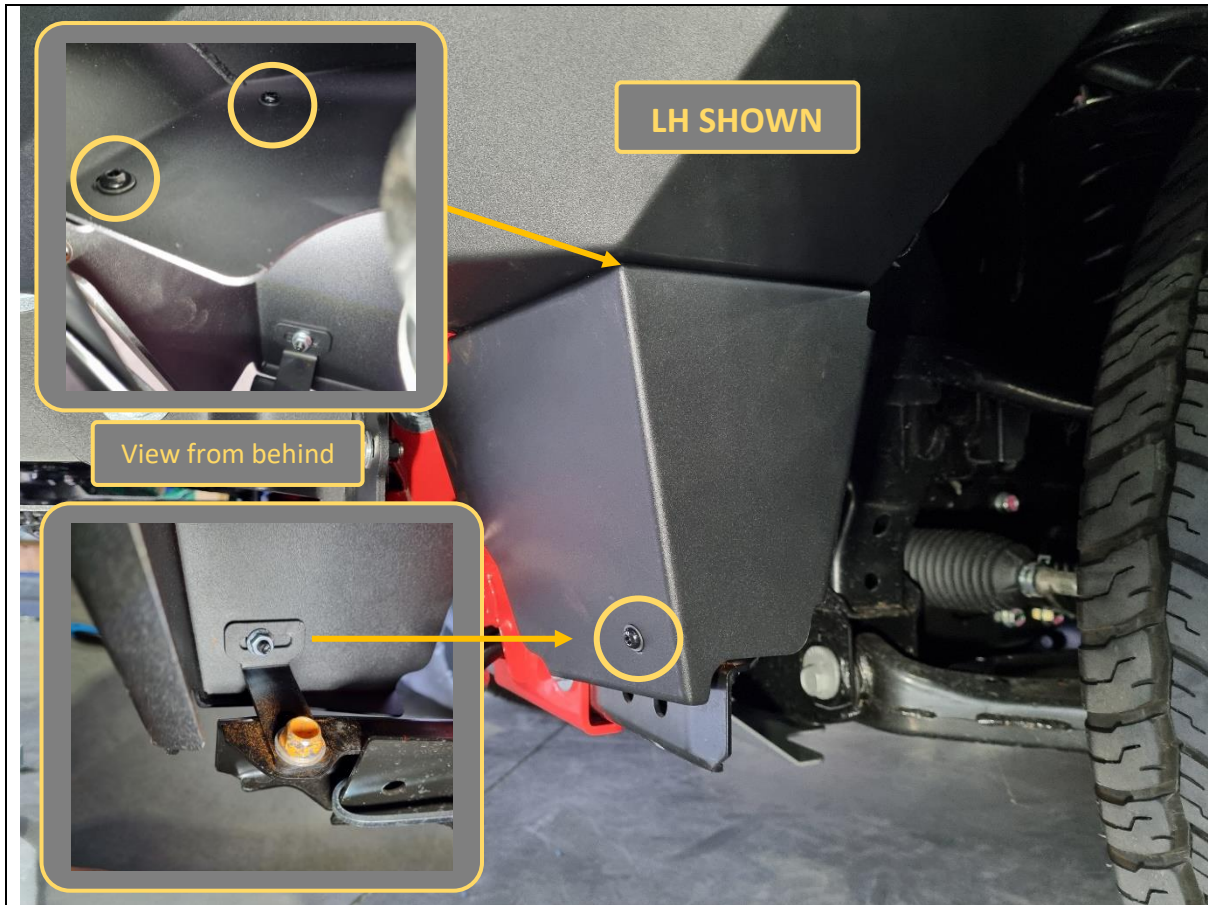

<p>173. Fit the lower side underpanel to the car.</p> <p>174. Secure the top to the main side underpanel with 3x M6x16 black button head bolts and black washers. It is easiest to access through the rear with the inner wheel arch liner pulled out of the way.</p>	<p><b>TOOLS REQUIRED</b></p> <p>4mm hex/Allen key</p> <p>14mm socket/spanner</p>
<p>175. Re-fit all plastic push clips (see Step 25) holding the wheel arch liner to the car.</p> <p>176. Secure the bottom of the lower side underpanel to the mount with 1x M6x16 black button head bolt, black washer and flange nut. Secure the 14mm hex bolt.</p> <p>177. Repeat for other side.</p>	<p><b>FASTENERS</b></p> <p>8x M6x16 black button head bolts</p> <p>8x M6 black flat washers</p> <p>2x M6 flange nuts</p> <p>Plastic push clips (see Step 25)</p>



<p>178. Fit the compliance plate on the inside face of the LH lower side underpanel.</p> <p>179. Review fitment and double check all bolts are tightened correctly.</p> <p>180. Check all wiring is connected, and that fog lights, indicators (Toro only), camera, radars and parking sensors are all functional.</p>	<p><b>TOOLS REQUIRED</b></p>
	<p><b>FASTENERS</b></p>





**Congratulations! You're done!**  
**Head for the tracks and frighten others in your Triton!**